

# winterhalter

## Spare parts list STR

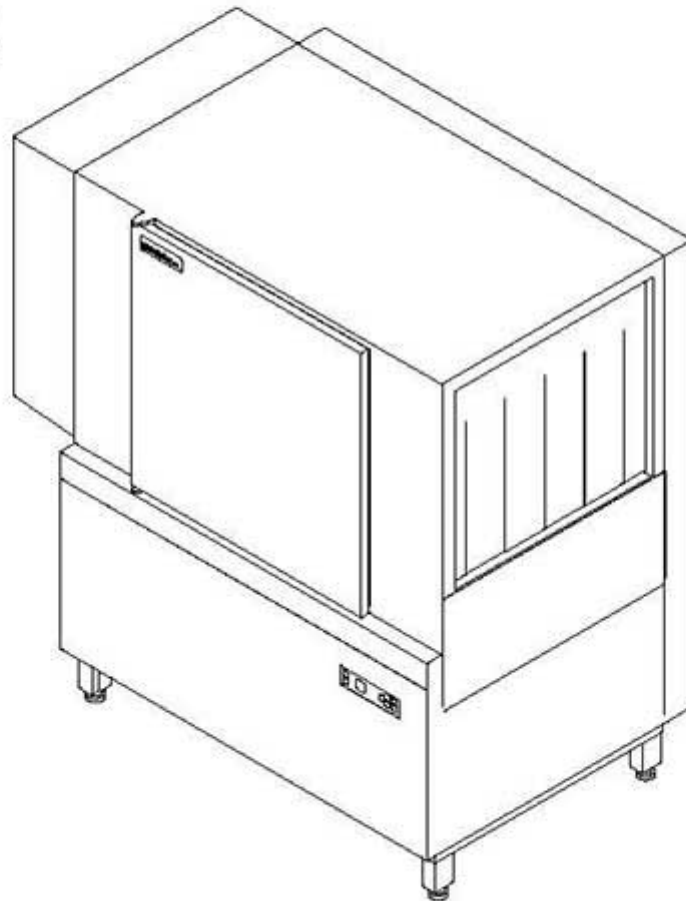

---

Drawn up: 12.09.07

Processed: 02.08.09

Parts no.: 89012426

## Contents

Water inlet	Page 1 - 2
Water drainage / Mediamat	Page 3 - 4
Wash pump	Page 5 - 6
Wash system, bottom	Page 7 - 8
Wash system, top	Page 9 - 10
Rinse system	Page 11 - 12
Pressure boiler	Page 13 - 14
Pressure-independent boiler	Page 15 - 18
Drive	Page 19 - 22
Rack guide I	Page 23 - 24
Rack guide II	Page 25 - 26
Push bars I	Page 27 - 28
Push bars II	Page 29 - 30
Base frame	Page 31 - 32
Housing	Page 33 - 34
Door	Page 35 - 36
Curtains	Page 37 - 38
Panelling	Page 39 - 40
Panelling	Page 41 - 42
Electric parts	Page 43 - 44
Vapour extraction	Page 45 - 46
Blower	Page 47 - 48
Stub roller tabling	Page 49 - 50
Steam heating	Page 51 - 54
Corner entry	Page 55 - 56

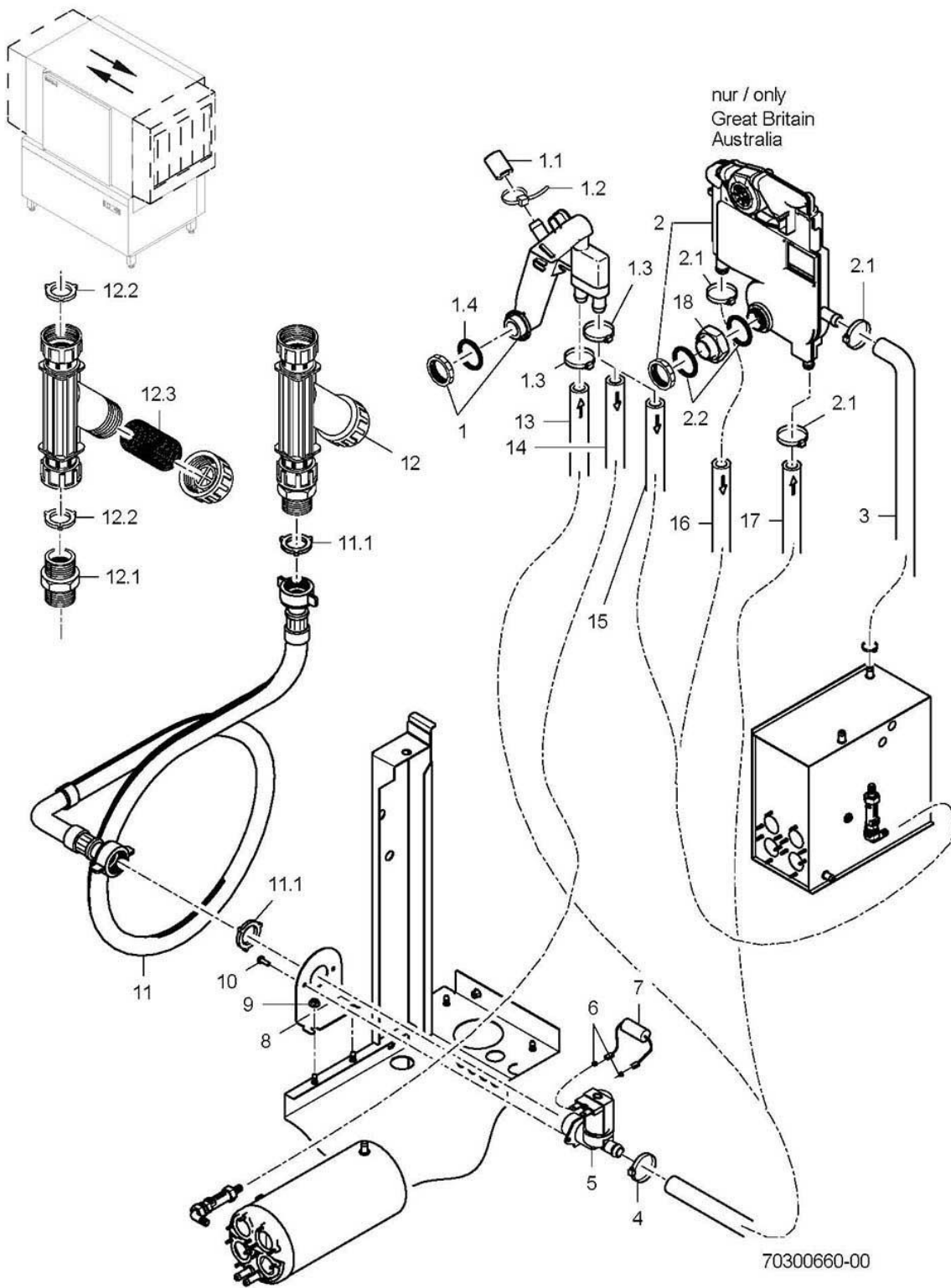

## STR

### Water inlet

Item.	Designation	Parts no.:	Pc.	Notes
1	Reverse flow inhibitor kit	60003846		incl. item 1.1 - 1.4
1.1	Round cap; D11 X 20	35 03 029		
1.2	Cable tie; 200 X 4,7	31 20 015		
1.3	Hose clamp; D12-22 X 9	28 02 105	4	
1.4	O-ring; 24 X 3,0	27 07 087		
2	Set of WSE without impeller counter	60003511		incl. item 2.1 - 2.2; Great Britain; Australia
2.1	Hose clamp; D12-22 X 9	28 02 105	3	
2.2	O-ring; 24 X 3,0	27 07 087	2	
3	Hose elbow 90°; DN12,5X4,0;40X1400	60001610		
4	Hose clamp; D12-22 X 9	28 02 105		
5	Solenoid valve flow restrictor 15l; 220-240V/50-60HZ	31 06 180		
5	15 l solenoid valve set; 200-240V/50-60HZ/+/-10%	60004148		Japan
5	5 l solenoid valve set; 200-240V/50-60HZ/+/-10%	60004147		Great Britain; Australia
6	Fast-on piggy-back plug	31 12 004	2	
7	RC element; 0,15 MICRO F; 3,3 KOHM	31 13 114		
8	Retainer; 1,5 X 78 X 105,8	70300043		
9	Ratchet nut; M5	21 01 310	2	
10	Countersunk screw; M4 X 8	20 10 309	2	
11	Water supply hose; DN13 X 3,5; 2500	40 02 060		incl. item 11.1
11.1	Gasket; D16 X D24 X 3,0	80002241	3	
12	Dirt trap; 150 µM	80002153		incl. item 12.1 - 12.3
12.1	Double nipple; G 3/4" X 40; SW30	80002167		
12.2	Gasket; D16 X D24 X 3,0	80002241	2	
12.3	Strainer; D27 X 67 X 150µM	80002728		
13	Industrial hose; DN13 X 3,5	40 02 035		1400 mm; "By-the-metre" goods
14	Industrial hose; DN13 X 3,5	40 02 035		1500 mm; "By-the-metre" goods
15	Hose elbow 90°; DN12,5X4,0;40X1400	60001610		
16	Reducing hose; DN10 X DN13; 55 X 1090	65005358		
17	Industrial hose; DN13 X 3,5	40 02 035		1400 mm; "By-the-metre" goods
18	Extension; D20 X 21; SW36	61005911		
o.P.	Solenoid valve cable; 2 X 0,75QMM; 1400 LG	70300498		

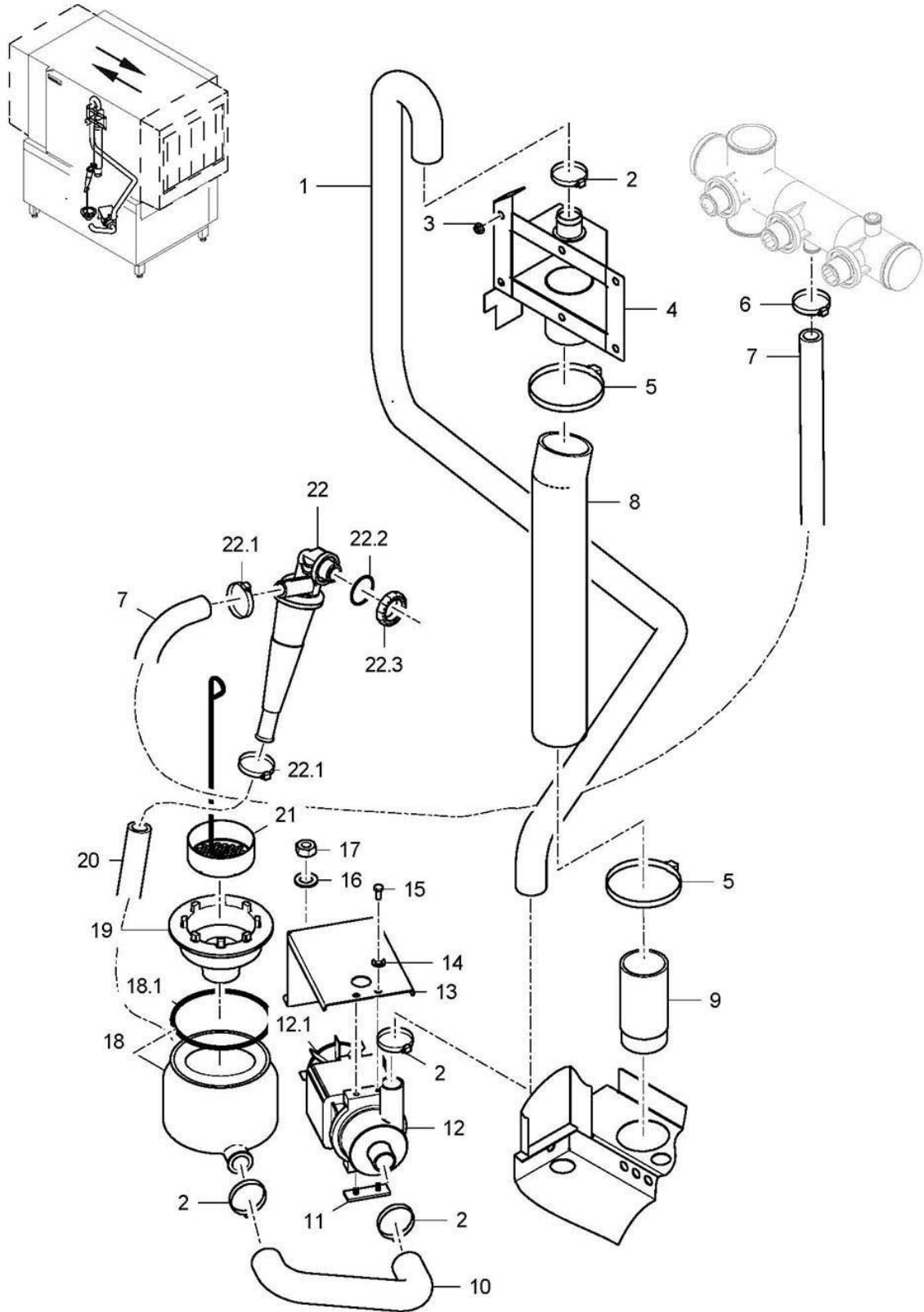

70300661-00

## STR

### Water drainage / Mediamat

Item.	Designation	Parts no.:	Pc.	Notes
1	Moulded hose; DN24 X 4,0	70300391		
2	Hose clamp; D24-36 X 12	28 02 111		
3	Ratchet nut; M5	21 01 310	6	
4	Drain housing	70300492		
5	Hose clamp; D47-67 X 12	28 02 115		
6	Hose clamp; D20-30 X 12	28 02 109		
7	Moulded hose; DN16 X 4; 90GRAD	70005415		
8	Moulded hose; DN49 X 4,0	61005530		
9	Drain adapter; D50 X G1 1/2" X 100	62001497		
10	Hose bend; DN24 X 4,0	70300392		
11	Spacer; 3,0 X 16 X 46	61006026		
12	3/0 lye pump; 200-240V/50-60HZ	31 02 410		incl. item 12.1
12.1	Fan blade	31 02 431		
13	Holder; 1,5 X 110,84 X 253,66	61005154		
14	Spring washer; B6	23 03 300	2	
15	Hexagon screw; M6 X 10; A70	20 01 332	2	
16	Washer; D5,3 X D15 X 1,2	22 05 301	2	
17	Hexagonal nut; M5 SELBSTSICHERND	21 05 302	2	
18	Sump pot	61005186		incl. item 18.1
18.1	O-ring; 91 X 3,5	27 07 075		
19	Sump drain set	61006178		
20	Form hose; DN15,5 X 4,0	70300653		
21	Sump filter; D70	65005555		
22	Mediamat Cyclo	61005184		incl. item 22.1 - 22.3
22.1	Hose clamp; D12-22 X 9	28 02 105	2	
22.2	O-ring; 20 X 3,5	27 07 040		
22.3	Tank inlet set; G 1/2" X 8; SW27	61005339		

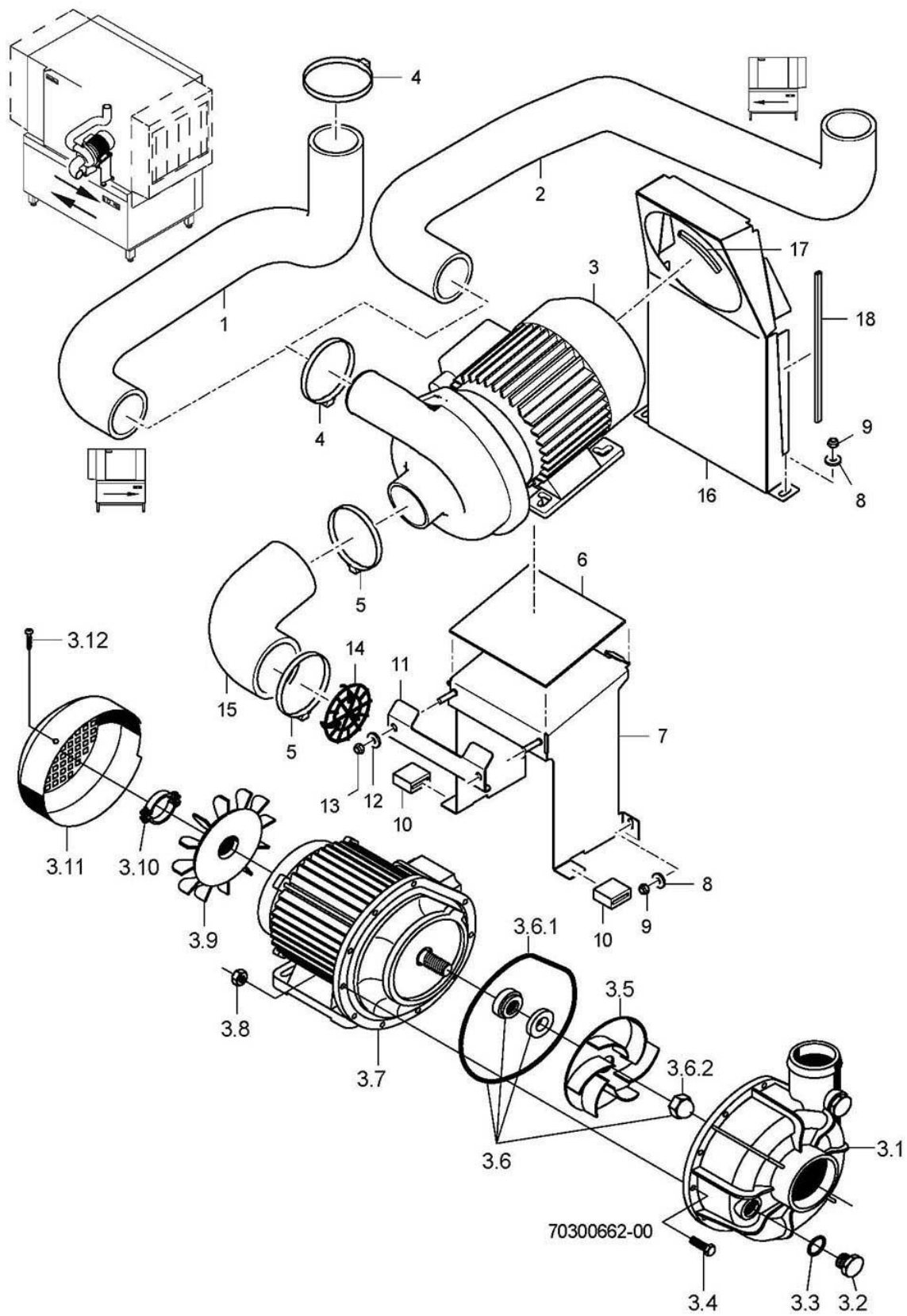

## STR

### Wash pump

Item.	Designation	Parts no.:	Pc.	Notes
1	Hose bend L-R; DN50 X 6,0	70300390		
2	Hose bend R-L; DN50 X 6,0	70300239		
3	Pump 1.1 kW 2/1; 230V/400V/3/50HZ; IP44	31 02 263		incl. item 3.1 - 3.12 turn motor
3	Pump 1.1 kW 2/1; 230V/400V/3/60HZ; IP44	31 02 267		incl. item 3.1 - 3.12 turn motor
3	Pump 1.1 kW 2/1; 200V/3/50HZ; IP44	31 02 302		incl. item 3.1 - 3.12 turn motor
3	Pump 1.1 kW 2/1; 200V/3/60HZ	31 02 303		incl. item 3.1 - 3.12 turn motor
3	Pump 1.1 kW 9/1; 254V/440V/3/60HZ; IP55	31 02 416		incl. item 3.1 - 3.12 turn motor
3.1	Pump housing	31 02 204		
3.2	Dummy plug; G 1/2" X 20,5	35 01 108		
3.3	O-ring; 20 X 3,5	27 07 040		
3.4	Hexagon screw; M4 X 25; 8.8	20 01 020		
3.5	Pump impeller; D111	31 02 273		for 50 Hz pumps
3.5	Pump impeller; D96	31 02 274		for 60 Hz pumps
3.6	Gasket set; 1,1/1,7/1,85/0,73 KW	80002670		
3.6.1	O-ring; 158,35 X 3,53	31 02 209		
3.6.2	Cap nut; M8 SELBSTSICHERND	21 10 305		
3.7	Pump cover	31 02 208		
3.8	Hexagonal nut; M4	21 01 302		
3.9	Fan blade; 1,1 / 1,5 KW	31 02 211		
3.10	Fixing clamp	31 02 218		
3.11	Fan hood; 1,1 / 1,5 KW	31 02 212		
3.12	Raised head screw; M4 X 8	20 10 310		
4	Hose clamp; D47-67 X 12	28 02 115	2	
5	Hose clamp; D62-82 X 12	28 02 137	2	
6	Support; 3,0 X 130 X 154	70006821		
7	Support assembly	70300108		
8	Washer; D5,3 X D15 X 1,2	22 05 301	2	
9	Hexagonal nut; M5 SELBSTSICHERND	21 05 302	2	
10	Buffer; 14 X 28 X 31	61005067	2	
11	Holder; 2,0 X 60,11 X 154	70006822		
12	Washer; D6,4 X D18 X 1,6	22 05 302	2	
13	Hexagonal nut; M6 SELBSTSICHERND	21 05 304	2	
14	Inline filter; D72	62001956		
15	Hose elbow; DN62 X 7,0	65004103		
16	Air baffle; 0,8 X 272,4 X 444,29	70300420		
17	Sealing profile; 1,0 - 2,0MM	40 04 006		460 mm; "By-the-metre" goods
18	Sealing profile; 1,0 - 2,0MM	40 04 006		810 mm; "By-the-metre" goods
o.P.	Wash pump cable	70300405		



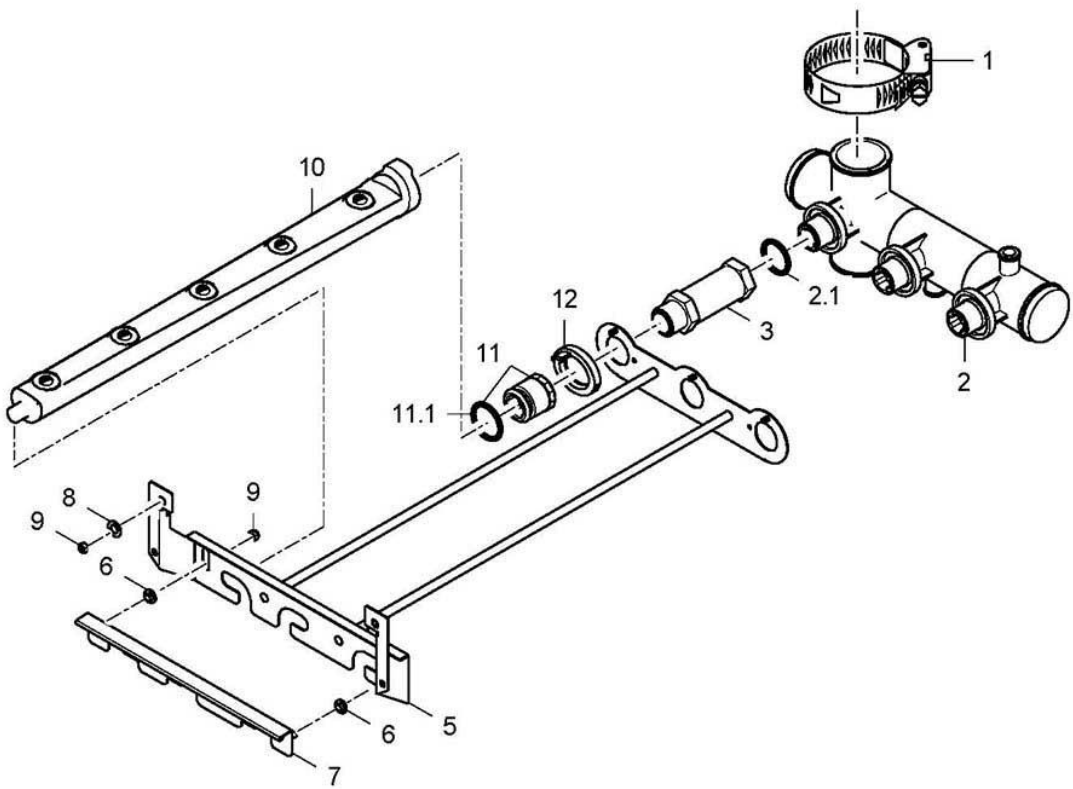
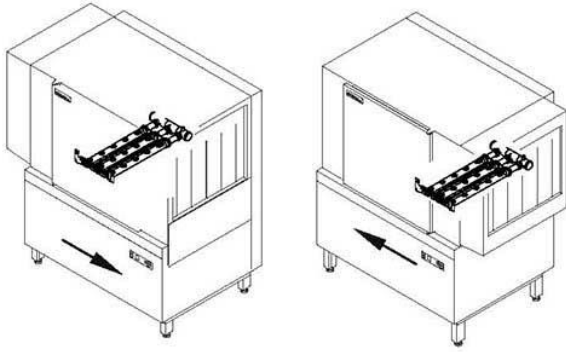

70300663-00

## STR

### Wash system, bottom

Item.	Designation	Parts no.:	Pc.	Notes
1	Hose clamp; D47-67 X 12	28 02 115		
2	Wash distributor, bottom, set; 294,5 LG	70008918		incl. item 2.1
2.1	O-ring; 29,5 X 4,5	27 07 008	3	
3	Extension piece; RD26X1/8X95,50; SW32	70003085	3	
5	Wash arm retainer, welded	70300301		
6	Bushing; D8 X 4; D12	70007667		
7	Shutter	70300303		
8	Washer; D5,3 X D15 X 1,2	22 05 301	2	
9	Hexagonal nut; M5 SELBSTSICHERND	21 05 302	2	
10	Wash arm; 5 DÜSEN; 472 LG	70005762	3	
11	Locking nut	60002785	3	incl. item 11.1
11.1	Seal ring; D26 X D32,5 X 5,0	70009122		
12	Locking ring; D49 X 19,5	60002652		

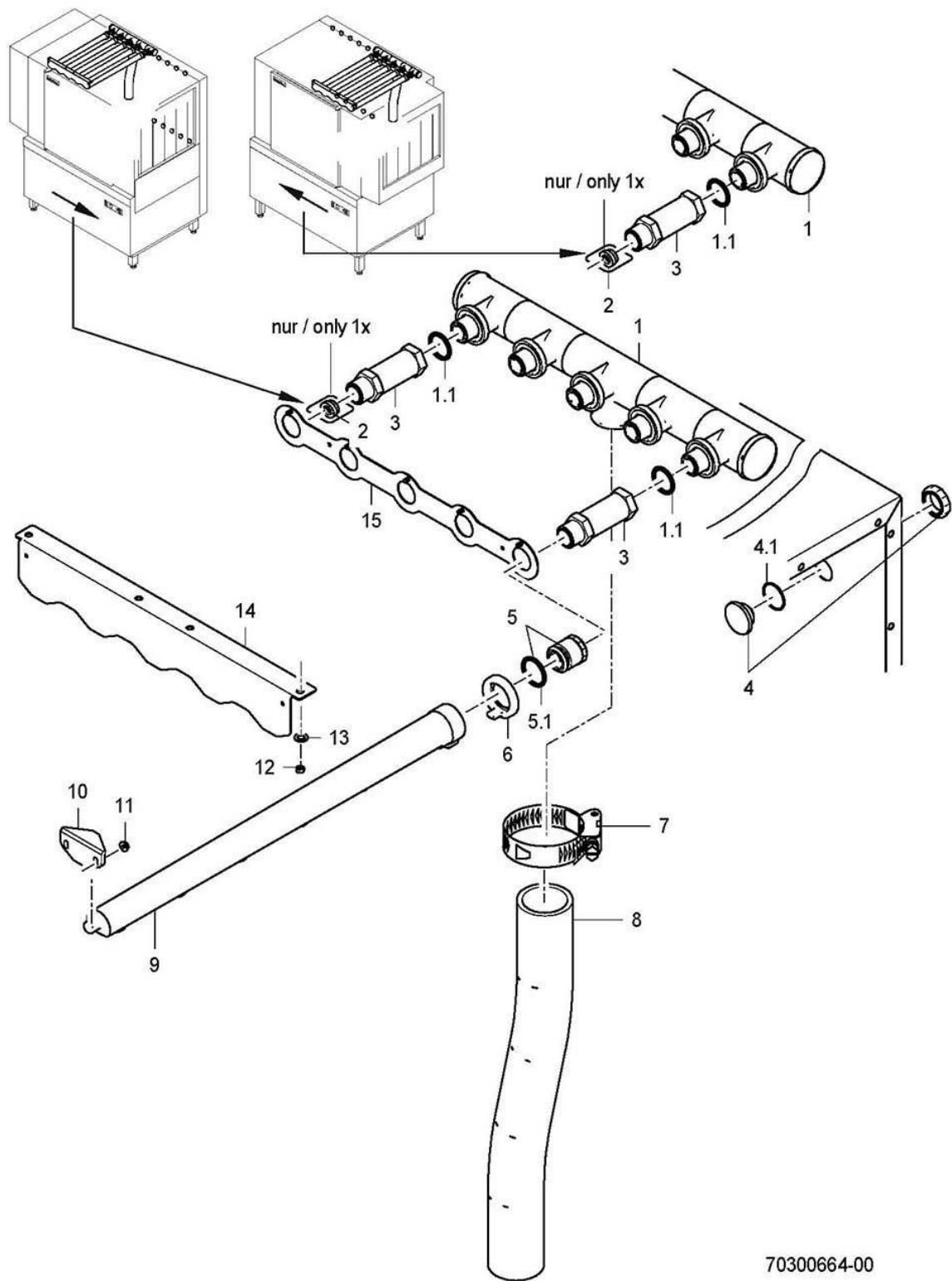

70300664-00

## STR

### Wash system, top

Item.	Designation	Parts no.:	Pc.	Notes
1	Wash distributor, top, set; 456 LG	70008916		incl. item 1.1
1.1	O-ring; 29,5 X 4,5	27 07 008	5	
2	Restrictor; D11 X D23,2 X 9,0	70006466	1	
3	Extension piece; RD26X1/8X 53; SW32	71001455	5	
4	Dummy plug; G 3/4" X 21,7;SW10;SW5	70005109	5	incl. item 4.1
4.1	O-ring; 26 X 2,5	27 07 062		
5	Locking nut	60002785	5	incl. item 5.1
5.1	Seal ring; D26 X D32,5 X 5,0	70009122		
6	Locking ring; D49 X 19,5	60002652	5	
7	Hose clamp; D47-67 X 12	28 02 115		
8	Industrial hose; DN50 X 6,0	40 02 006		540 mm; "By-the-metre" goods
9	Wash arm; 6 DÜSEN; 568 LG	71001453	5	
10	Snapper; 23,5 X 32 X 64	70008382	5	
11	Ratchet nut; M5	21 01 310	10	
12	Hexagonal nut; M5 SELBSTSICHERND	21 05 302	4	
13	Washer; D5,3 X D10 X 1,0	22 01 300	4	
14	Wash arm retainer	70300129		
15	Plate	70300131		

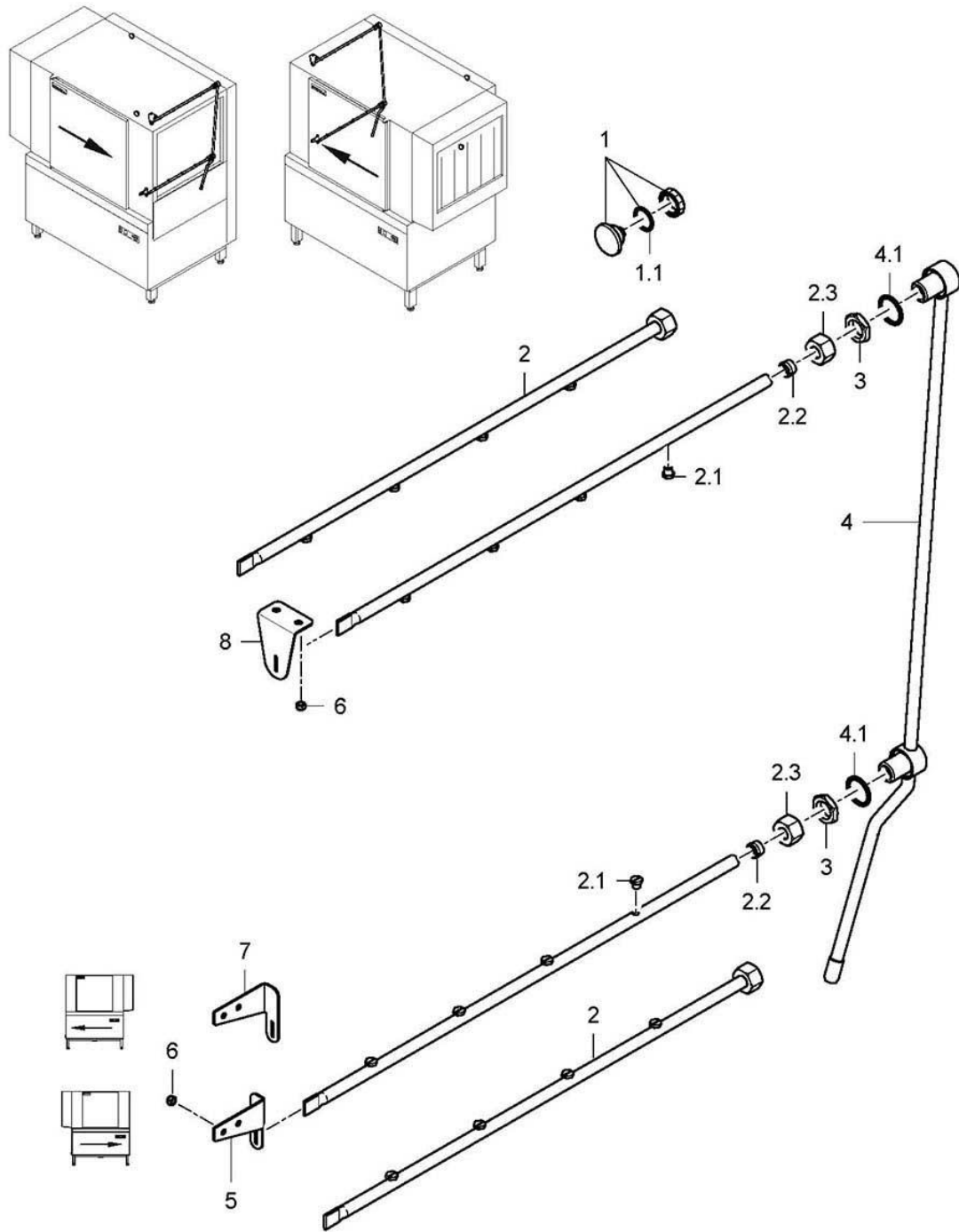

70300665-00

## STR

### Rinse system

Item.	Designation	Parts no.:	Pc.	Notes
1	Dummy plug; G 3/8" X 21,4; SW10;	70004899		incl. item 1.1
1.1	O-ring; 16 X 2,5	27 07 001		
2	Rinse pipe; 4 DÜSEN, 586 LG	70300684		incl. item 2.1 - 2.2
2.1	Flat jet nozzle; 1/16 NPT; SW10	29 10 312	4	
2.2	Cutting ring; D12 X 10	29 07 304		
2.3	Union nut; G 1/2" X D12,2; SW24	29 07 301		
3	Hexagonal nut; G 1/2" X 6; SW27	61004994	2	
4	Rinse manifold	70300685		incl. item 4.1
4.1	O-ring; 20 X 3,5	27 07 040		
5	Retainer L-R; 2,0 X 63 X 85,3	70300342		
6	Hexagonal nut; M5 SELBSTSICHERND	21 05 302		
7	Retainer R-L; 2,0 X 63 X 85,3	70300343		
8	Retainer; 2,0 X 50 X 88,8	70300056		

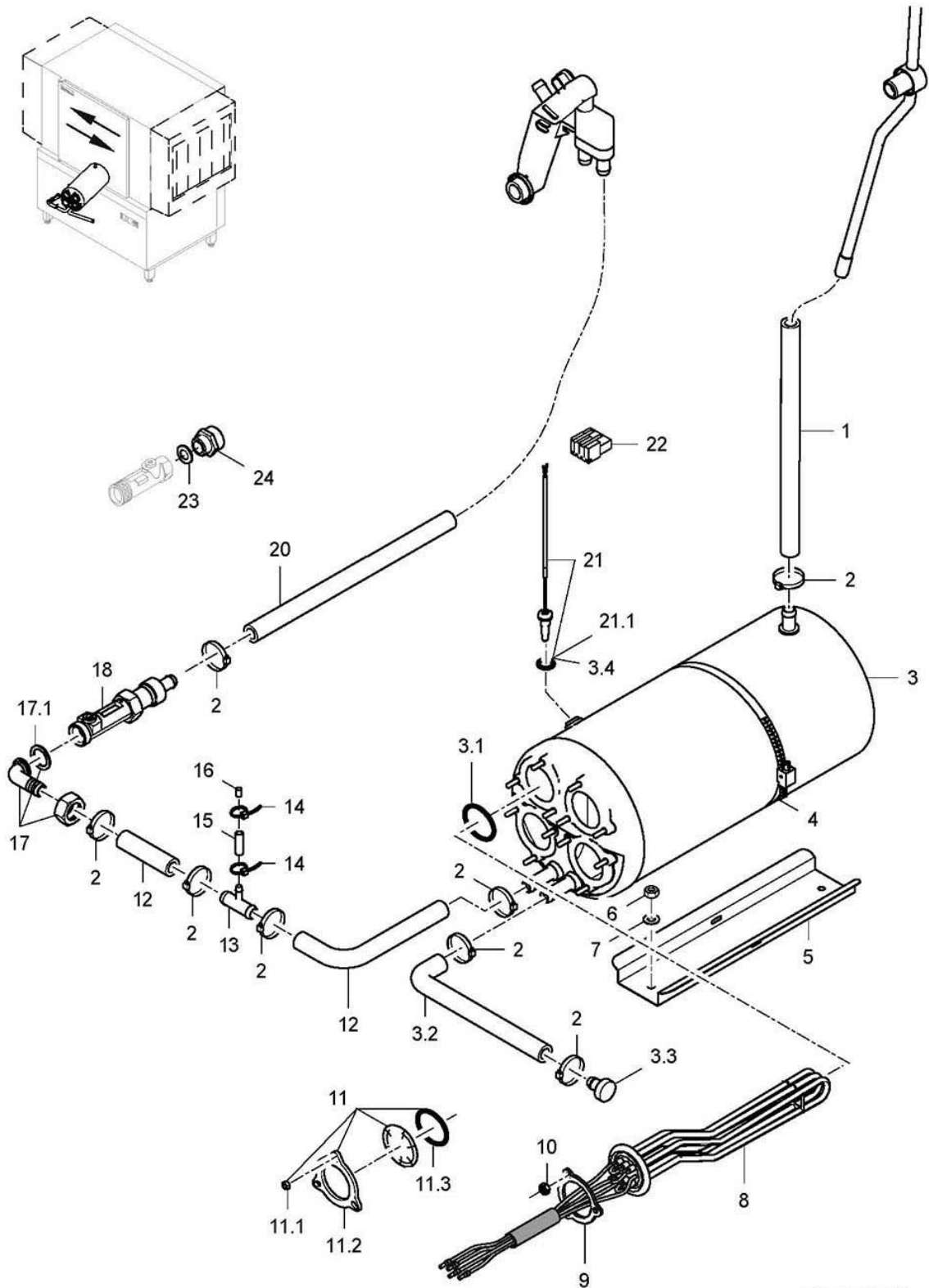

70300666-01

## STR

### Pressure boiler

Item.	Designation	Parts no.:	Pc.	Notes
1	Industrial hose; DN13 X 3,5	40 02 035		1400 mm; "By-the-metre" goods
2	Self-clamping hose clamp; D18,7 - 19,6	28 02 015		
3	4-hole boiler set	70008915		incl. item 3.1 – 3.4
3.1	O-ring; 43 X 7,0	27 07 088	4	
3.2	Hose elbow 90°; DN12,5 X 4,0; 40 X 200	65005547		
3.3	Plug; D24 X D13,1 X 27	70007962		
3.4	O-ring; 10 X 1	27 07 054		
4	Hose clamp; D50-215 X 12	28 02 126		
5	Boiler support; 1,0 X 122 X 300	70007924		
6	Hexagonal nut; M5 SELBSTSICHERND	21 05 302	2	
7	Washer; D5,3 X D15 X 1,2	22 05 301	2	
8	6.0 kW heating element with fuse; 3 X 400V	31 03 150		
8	6.0 kW heating element with fuse; 3 X 420V	31 03 152		
8	6.0 kW heating element with fuse; 3 X 420V	31 03 182		Australia
8	6.0 kW heating element with fuse; 3 X 200V	31 03 151		
8	6.0 kW heating element with fuse; 3 X 230V	31 03 158		
8	6.0 kW heating element with fuse; 3 X 440V	31 03 153		
9	Locking washer; D43 X D80 X 4,0	01 17 003		
10	Hexagonal nut; M5	21 01 203		
11	Blind flange	60002787		incl. item 11.1 - 11.3
11.1	Hexagonal nut; M5	21 01 203	3	
11.2	Locking washer; D43 X D80 X 4,0	01 17 003		
11.3	O-ring; 43 X 7,0	27 07 088		
12	Hose bend; DN13 X 4,0	40 03 053		
13	Hose T-connecting piece; D15 X D15 X D10	70010599		
14	Cable tie; 100 X 2,5	31 20 175	2	
15	Hose; DN5 X 1,5	40 01 024		60 mm; "By-the-metre" goods
16	Bolt; D6 X 30	70200383		
17	Hose nipple, angled; D18	60002474		incl. item 17.1
17.1	Gasket; D16 X D24 X 3,0	80002241		
18	Flow regulator; 2 - 8 L/MIN	70010787		
20	Industrial hose; DN13 X 3,5	40 02 035		1500 mm; "By-the-metre" goods
21	Thermosensor set	71002591		incl. item 21.1
21.1	O-ring; 10 X 1	27 07 054		
22	Macro-module plug; RAST5; 2-POLIG; UNCOD.	31 12 091		
23	Gasket; D20,9 X D27 X 2,0	27 04 006		
24	Reducing nipple; G 1/2" X G 3/4"; SW27	61003430		



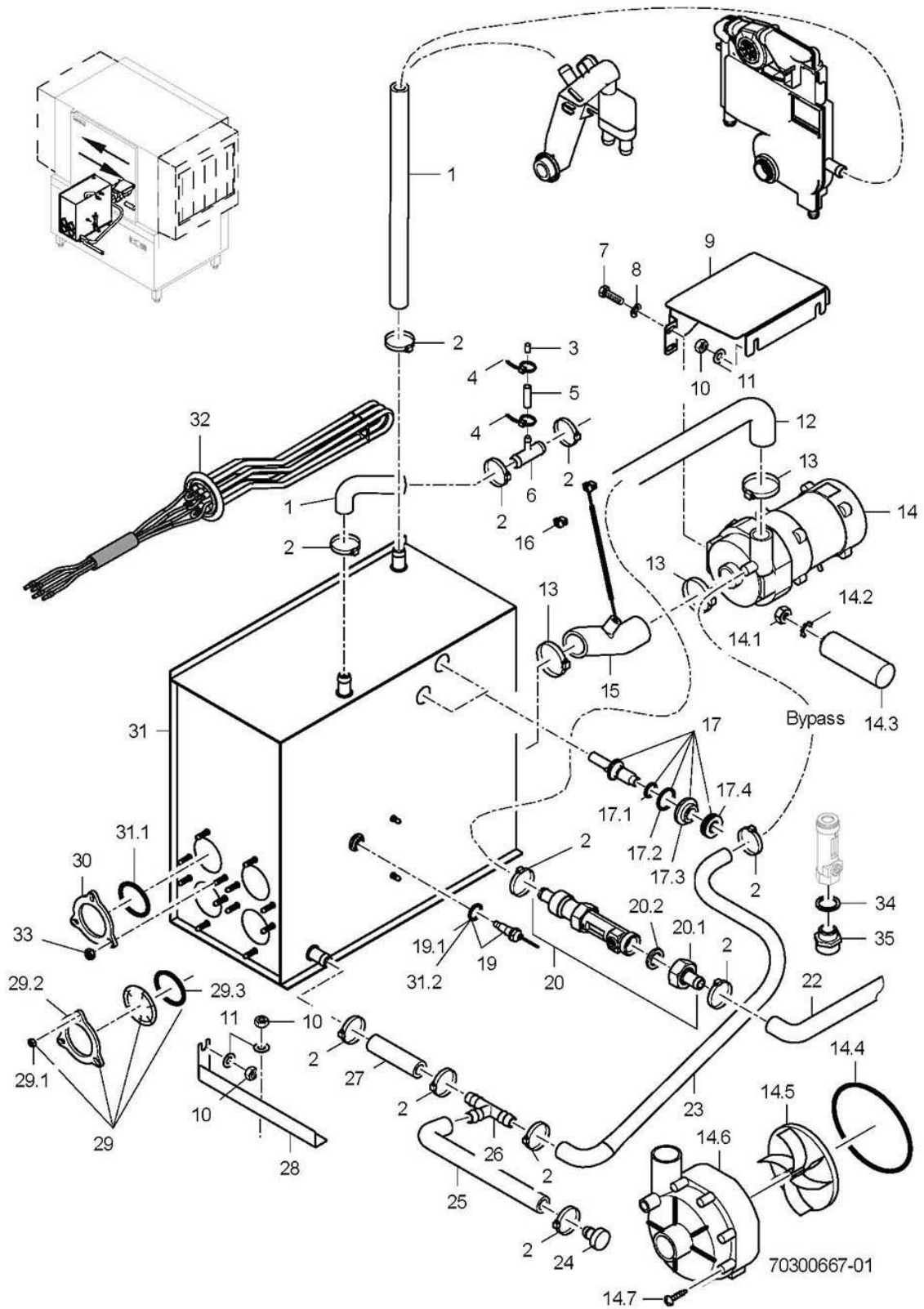

**STR****Pressure-independent boiler**

Item.	Designation	Parts no.:	Pc.	Notes
1	Hose elbow 90°; DN12,5X4,0;40X1400	60001610		
2	Hose clamp; D12-22 X 9	28 02 105		
3	Bolt; D6 X 30	70200383		
4	Cable tie; 100 X 2,5	31 20 175	2	
5	Hose; DN5 X 1,5	40 01 024		60 mm; "By-the-metre" goods
6	Hose T-connecting piece; D15 X D15 X D10	70010599		
7	Hexagon screw; M6 X 16; A70	20 01 306	2	
8	Spring washer; B6	23 03 300	2	
9	Retainer; 1,5 X 188,7 X 210,1	70300310		
10	Hexagonal nut; M5 SELBSTSICHERND	21 05 302		
11	Washer; D5,3 X D15 X 1,2	22 05 301		
12	Reducing elbow; DN12,5 X DN25	70300846		
13	Hose clamp; D24-36 X 12	28 02 111		
14	Pump 0.270 kW 8/0; 220/240V/1/50HZ	31 02 477		Repair recommended only for pump housings with 7 screws
14	Pump 0.270 kW 8/0; 220/240V/1/60HZ	31 02 445		Repair recommended only for pump housings with 7 screws
14	Pump 0.270 kW 8/0; 200V/1/50HZ	31 02 446		Repair recommended only for pump housings with 7 screws
14	Pump 0.270 kW 8/0; 200V/1/60HZ	31 02 447		Repair recommended only for pump housings with 7 screws
14.1	Hexagonal nut; M8	21 01 305		
14.2	Spring washer; B8	23 03 301		
14.3	Capacitor; 5 MIKRO F	31 13 099		
14.4	Cord; D=78 X 3; SHOR 50-55;	40 04 023		
14.5	Pump impeller; FÜR UP60/UP30 MIT 50HZ	31 02 466		50 Hz
14.5	Pump impeller, installed; FÜR UP60 MIT 60HZ	31 02 587		60 Hz
14.6	Pump housing; D=80,5MM	31 02 519		
14.7	Screw for pump housing	31 01 118	7	
15	Thermal sensor NSF	61006359		for temperature display
16	Macro-module plug; RAST5; 2-POLIG; UNCOD.	31 12 091		
17	Floating switch installation set	55 28 255	2	incl. item 17.1 - 17.4
17.1	O-ring; 11,11 X 1,78	27 07 079		
17.2	O-ring; 23 X 3,5	27 07 093		
17.3	Ring; D14,3 X D32 X 11	60003943		
17.4	Nut; M14 X 2, D26,8 X 8	60003989		
19	Thermosensor set	71002591		incl. item 19.1; for temperature control
19.1	O-ring; 10 X 1	27 07 054		

For missing items, see next page

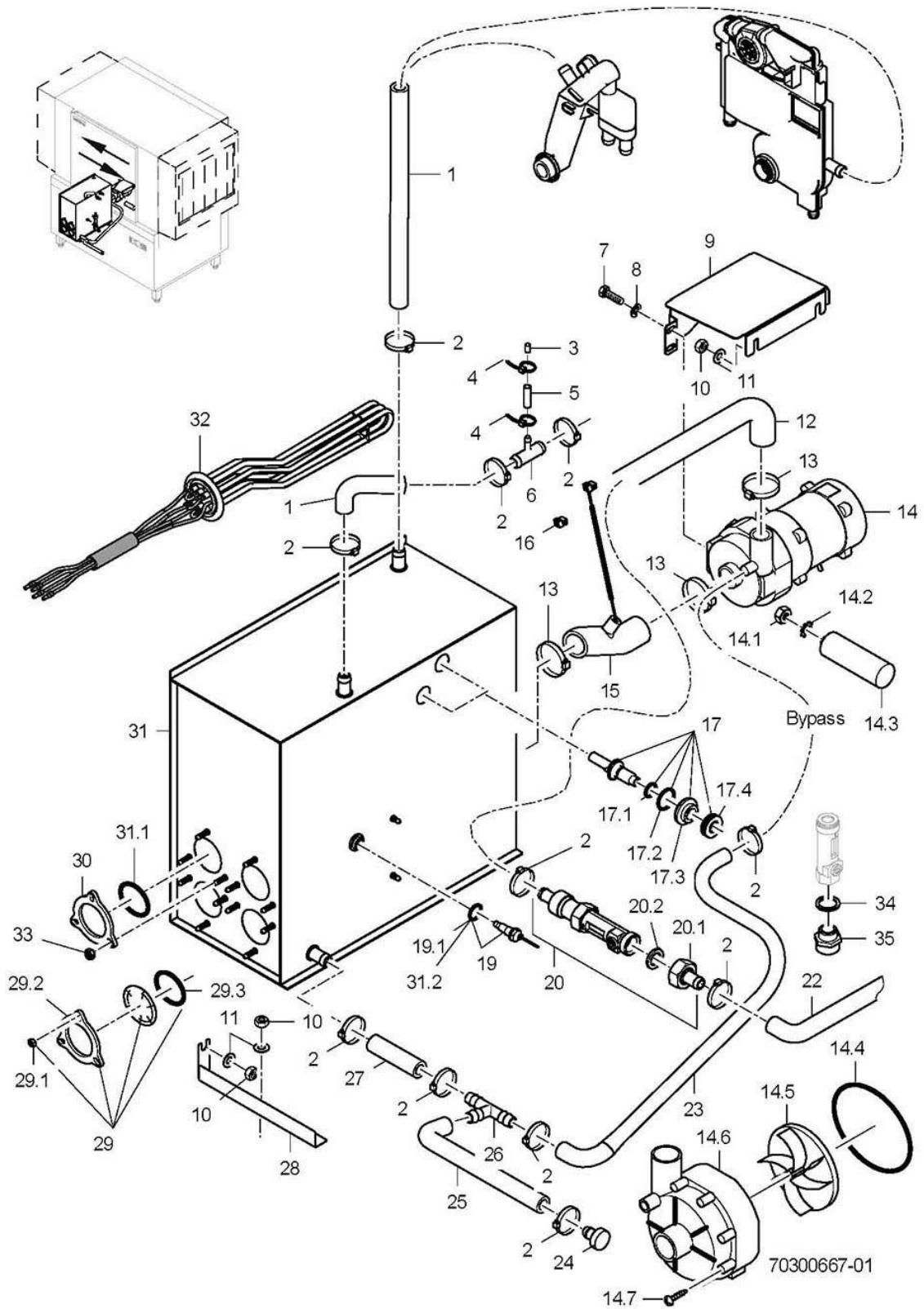

## STR

### Pressure-independent boiler

Item.	Designation	Parts no.:	Pc.	Notes
20	Flow regulator; 2 - 8 L/MIN	70010787		incl. item 20.1 - 20.2
20.1	Hose coupling; R 3/4" X 1/2"	60002453		
20.2	Gasket; D16 X D24 X 3,0	80002241		
22	Hose elbow 90°; DN12,5X4,0;45X880	62001434		
23	Reducing hose; DN10 X DN13; 55 X 1090	65005358		
24	Plug; D24 X D13,1 X 27	70007962		
25	Hose elbow 90°; DN12,5 X 4,0; 40 X 200	65005547		
26	Hose T-connecting piece; D15 X D15 X D15	70010598		
27	Industrial hose; DN13 X 3,5	40 02 035		60 mm; "By-the-metre" goods
28	Retainer; 1,0 X 39,6 X 236,6	70300313	2	
29	Blind flange	60002787		incl. item 29.1 - 29.3
29.1	Hexagonal nut; M5	21 01 203		
29.2	Locking washer; D43 X D80 X 4,0	01 17 003		
29.3	O-ring; 43 X 7,0	27 07 088		
30	Locking washer; D43 X D80 X 4,0	01 17 003		
31	Boiler set, four holes	70300686		incl. item 31.1 - 31.2
31.1	O-ring; 43 X 7,0	27 07 088	4	
31.2	O-ring; 10 X 1	27 07 054		
32	6.0 kW heating element with fuse; 3 X 400V	31 03 150		
32	6.0 kW heating element with fuse; 3 X 420V	31 03 152		
32	6.0 kW heating element with fuse; 3 X 420V	31 03 182		Australia
32	6.0 kW heating element with fuse; 3 X 200V	31 03 151		
32	6.0 kW heating element with fuse; 3 X 230V	31 03 158		
32	6.0 kW heating element with fuse; 3 X 440V	31 03 153		
33	Hexagonal nut; M5	21 01 203		
34	Gasket; D20,9 X D27 X 2,0	27 04 006		
35	Reducing nipple; G 1/2" X G 3/4"; SW27	61003430		

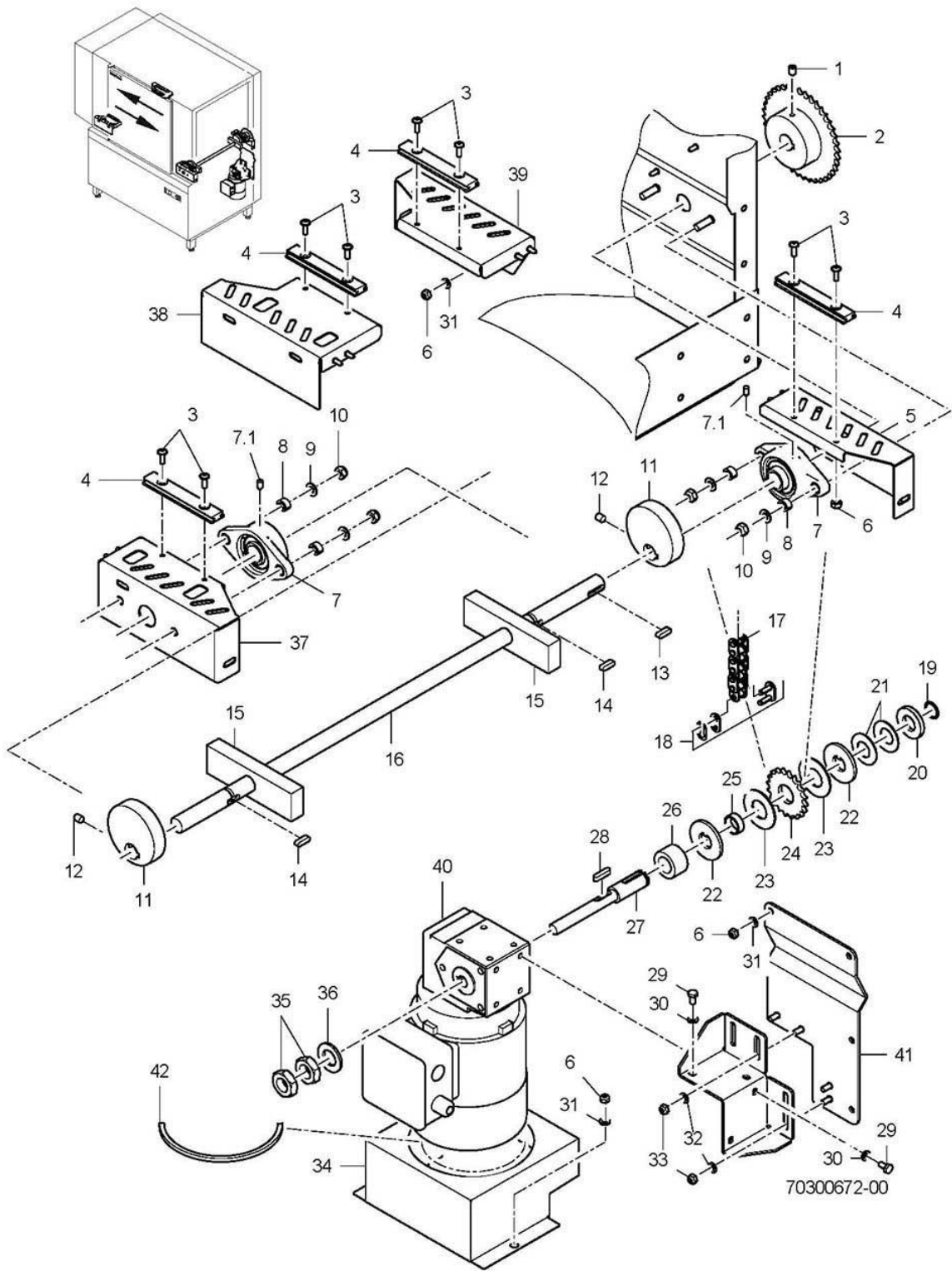

## STR

### Drive

Item.	Designation	Parts no.:	Pc.	Notes
1	Grub screw, M6 X 16	20 30 302		
2	Chain wheel 40 teeth; 3/8" X 7/32" X 28	70300397		50 Hz
2	Chain wheel 32 teeth; 3/8" X 7/32" X 28	70300396		racks/hr: 100 / 155; 60 Hz
2	Chain wheel 45 teeth; 3/8" X 7/32" X 28	70300398		racks/hr: 70 / 110; 60 Hz
2	Chain wheel 38 teeth; 3/8" X 7/32" X 30	70002825		racks/hr: 130 / 208; 60 Hz
3	Raised head screw with hexagon socket; M5 X 16 MIT FLANSCH	20 10 307	8	
4	CF profile; 9 X 20 X 114	70300162	4	
5	Junction plate 1	70300158		
6	Hexagonal nut; M5 SELBSTSICHERND	21 05 302		
7	Bearing with housing	28 01 027	2	incl. item 7.1
7.1	Grub screw; M6 X 8	20 30 304	2	
8	Pipe; D10 X 0,75 X 10	70200405	4	
9	Washer; D8,4 X D17 X 1,6	22 01 303	4	
10	Hexagonal nut; M8 SELBSTSICHERND	21 05 306	4	
11	Eccentric; D78 X 18	70006680	2	
12	Grub screw; M8 X 12	20 30 301	2	
13	Parallel key; A6 X 6 X 25	70002435		
14	Parallel key; A6 X 6 X 20	26 10 300	2	
15	Bracket; 20 X 40 X 140	70300295	2	
16	Drive shaft; D20F8 X 701,5	70300189		
17	Roller chain; 3/8" X 7/32"	28 10 038		924 mm; by-the-metre goods; racks/hr: 70 / 110; 50 Hz
17	Roller chain; 3/8" X 7/32"	28 10 038		963 mm; by-the-metre goods; racks/hr: 70 / 110; 60 Hz
17	Roller chain; 3/8" X 7/32"	28 10 038		991 mm; by-the-metre goods; racks/hr: 100 / 155; 50Hz
17	Roller chain; 3/8" X 7/32"	28 10 038		896 mm; by-the-metre goods; racks/hr: 100 / 155; 60 Hz
17	Roller chain; 3/8" X 7/32"	28 10 038		943 mm; by-the-metre goods; racks/hr: 130 / 208; 50 Hz
17	Roller chain; 3/8" X 7/32"	28 10 038		972 mm; by-the-metre goods; racks/hr: 130 / 208; 60 Hz
18	Master link; 06 B-1	28 10 037		

For missing items, see next page

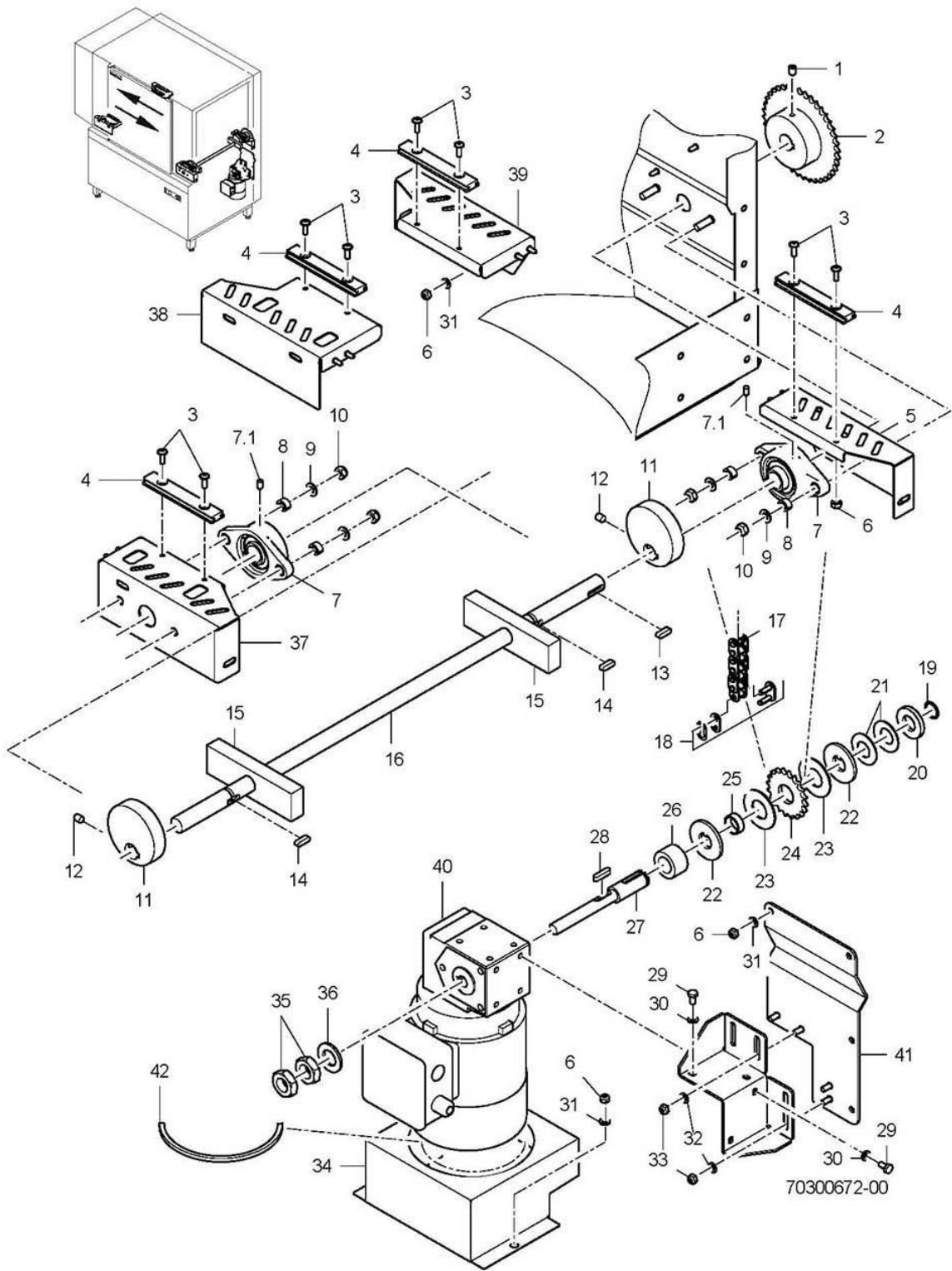

## STR

### Drive

Item.	Designation	Parts no.:	Pc.	Notes
19	Round wire circlip; D20	23 10 306		
20	Backup ring; D40 X 6	70008632		
21	Cup spring; D40 X 20,4 X 1,5	22 10 301	2	
22	Brake disc; D20,2 X D50 X 4,0	70200367	2	
23	Brake lining; D50 X 2	70200368	2	
24	Chain wheel 20 teeth; 3/8" X 7/32" X 5,3	70200370		racks/hr: 70 / 110; 50 Hz
24	Chain wheel 31 teeth; 3/8" X 7/32" X 5,3	70008375		racks/hr: 100 / 155; 50Hz
24	Chain wheel 20 teeth; 3/8" X 7/32" X 5,3	70200370		racks/hr: 100 / 155; 60 Hz
24	Chain wheel 31 teeth; 3/8" X 7/32" X 5,3	70008375		racks/hr: 130 / 208; 50+60 Hz
25	Bushing; D23,9 X 8	70200369		
26	Thrust ring; D20,2 X D35 X 21	70300272		
27	Spindle; D20 X 150	70300271		
28	Parallel key; 4,96 X 25	70300837		
29	Hexagon screw; M6 X 16; A70	20 01 306	4	
30	Spring washer; B6	23 03 300	4	
31	Washer; D5,3 X D15 X 1,2	22 05 301		
32	Washer; D6,4 X D18 X 1,6	22 05 302	4	
33	Hexagonal nut; M6 SELBSTSICHERND	21 05 304	4	
34	Air baffle; 0,8 X 317,8 X 388,6	70300524		
35	Hexagonal nut; M14 X 1,5	21 01 008	2	
36	Washer; B15; DIN 125	22 01 007		
37	Junction plate 2	70300159		
38	Junction plate 3	70300160		
39	Junction plate 4	70300161		
40	Drive motor 0.09/0.12 kW; 380-440V/3/50-60HZ	31 16 090		
40	Drive motor 0.09/0.12 kW; 220-240V/50-60HZ	31 16 091		
40	Drive motor 0.09/0.12 kW; 200V/3/50HZ-60HZ	31 16 092		
41	Support assembly	70300225		
42	Sealing profile; 1,0 - 2,0MM	40 04 006		460 mm; "By-the-metre" goods
o.P.	Drive cable	70300404		



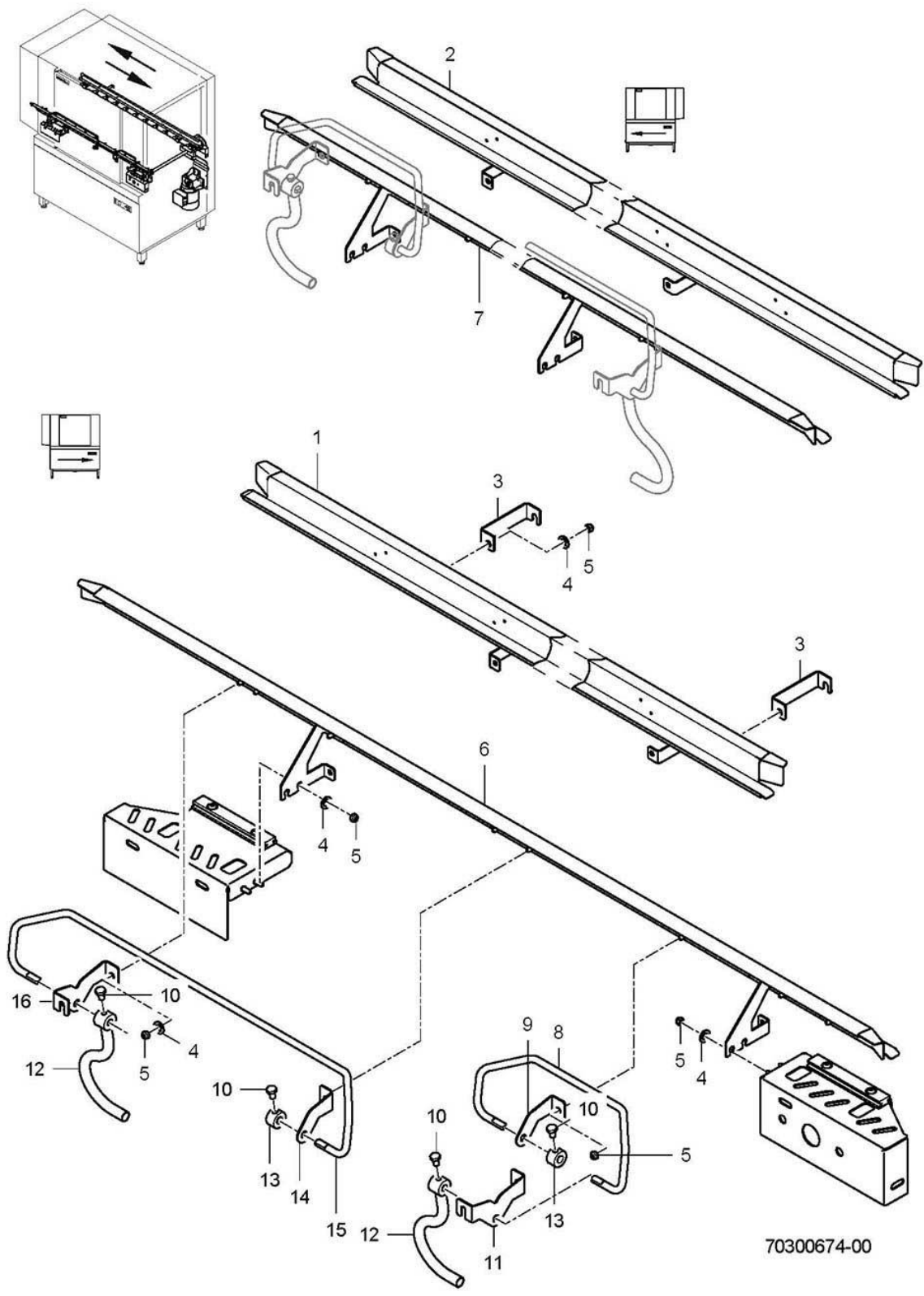

70300674-00

## STR

### Rack guide I

Item.	Designation	Parts no.:	Pc.	Notes
1	Rack rail	70300193		left - right
1	Rack rail	70300152		Optional: for machines 1110 mm (44 inches) in length; left - right
2	Rack rail	70300195		right - left
2	Rack rail	70300152		Optional: for machines 1110 mm (44 inches) in length; right - left
3	Support; 2,0 X 20 X 110,32	70300478	2	
4	Washer; D5,3 X D15 X 1,2	22 05 301		
5	Hexagonal nut; M5 SELBSTSICHERND	21 05 302		
6	Rack guide, front, R-L	70300202		left - right
6	Rack guide, front, L-R	70300153		Optional: for machines 1110 mm (44 inches) in length; left - right
7	Rack guide, front, R-L	70300230		right - left
7	Rack guide, front, R-L	70300156		Optional: for machines 1110 mm (44 inches) in length; right - left
8	Switch lever; D8 X 444	70300171		
9	Bracket 1; 2,0 X 44,6 X 122,3	70300499		
10	Hexagon screw; M6 X 10; A70	20 01 332	4	
11	Bracket 2; 2,0 X 44,6 X 122,3	70300501		
12	Switching bar	70300346	2	
13	Set collar; D20 X 12	70000595		
14	Right mount; 2,0 X 44,6 X 74,29	70300170		
15	Switch lever; D8 X 744	70300172		
16	Left mount; 2,0 X 44,6 X 74,29	70300169		

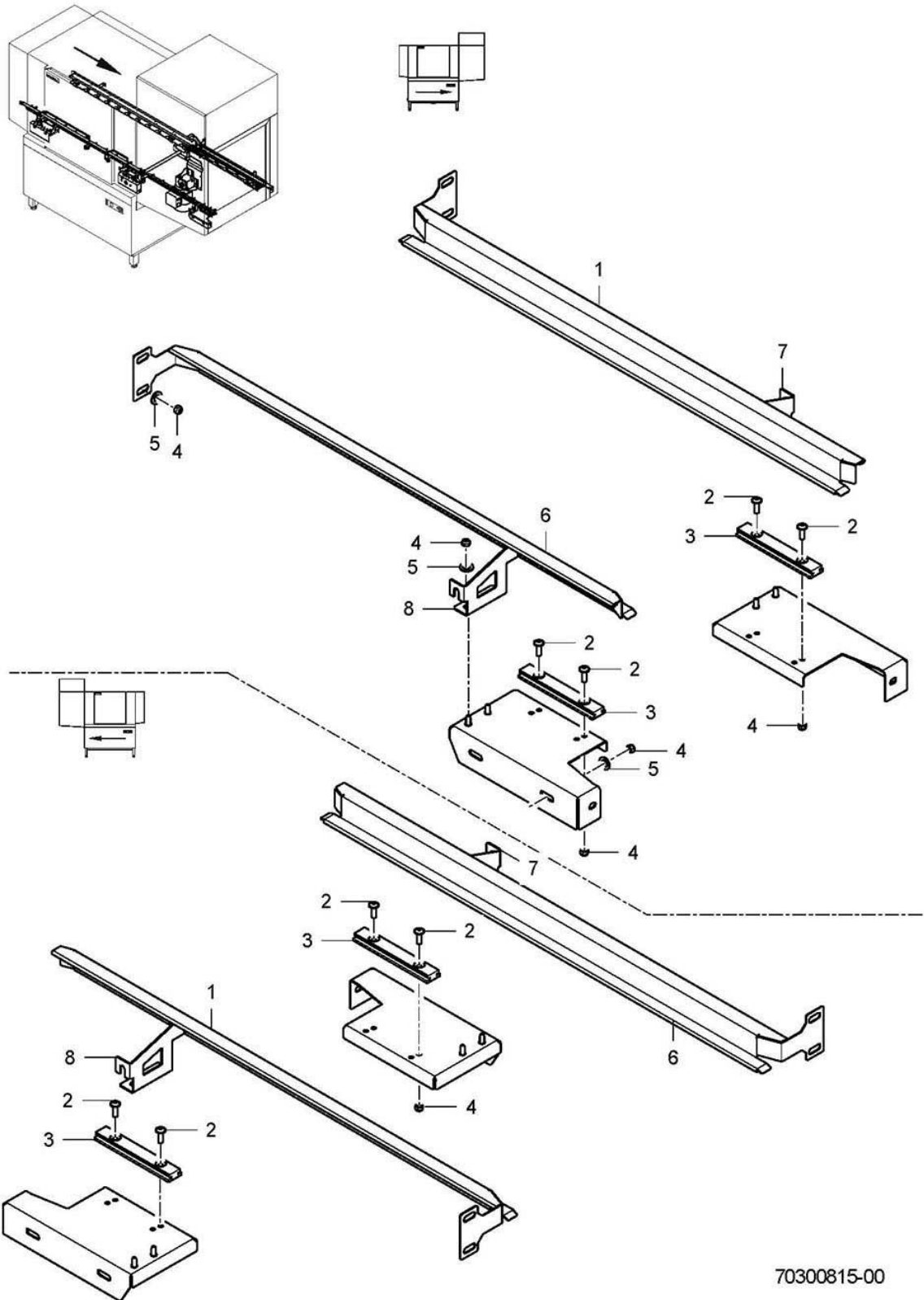

70300815-00

## STR

### Rack guide II

Item.	Designation	Parts no.:	Pc.	Notes
1	Rack guide	70300721		
2	Raised head screw with hexagon socket; M5 X 16 MIT FLANSCH	20 10 307	4	
3	CF profile; 9 X 20 X 114	70300162	2	
4	Hexagonal nut; M5 SELBSTSICHERND	21 05 302		
5	Washer; D5,3 X D15 X 1,2	22 05 301		
6	Rack guide	70300724		
7	Console; 2,0 X 84 X 111,5	70300718		
8	Console; 2,0 X 84 X 121,5	70300719		

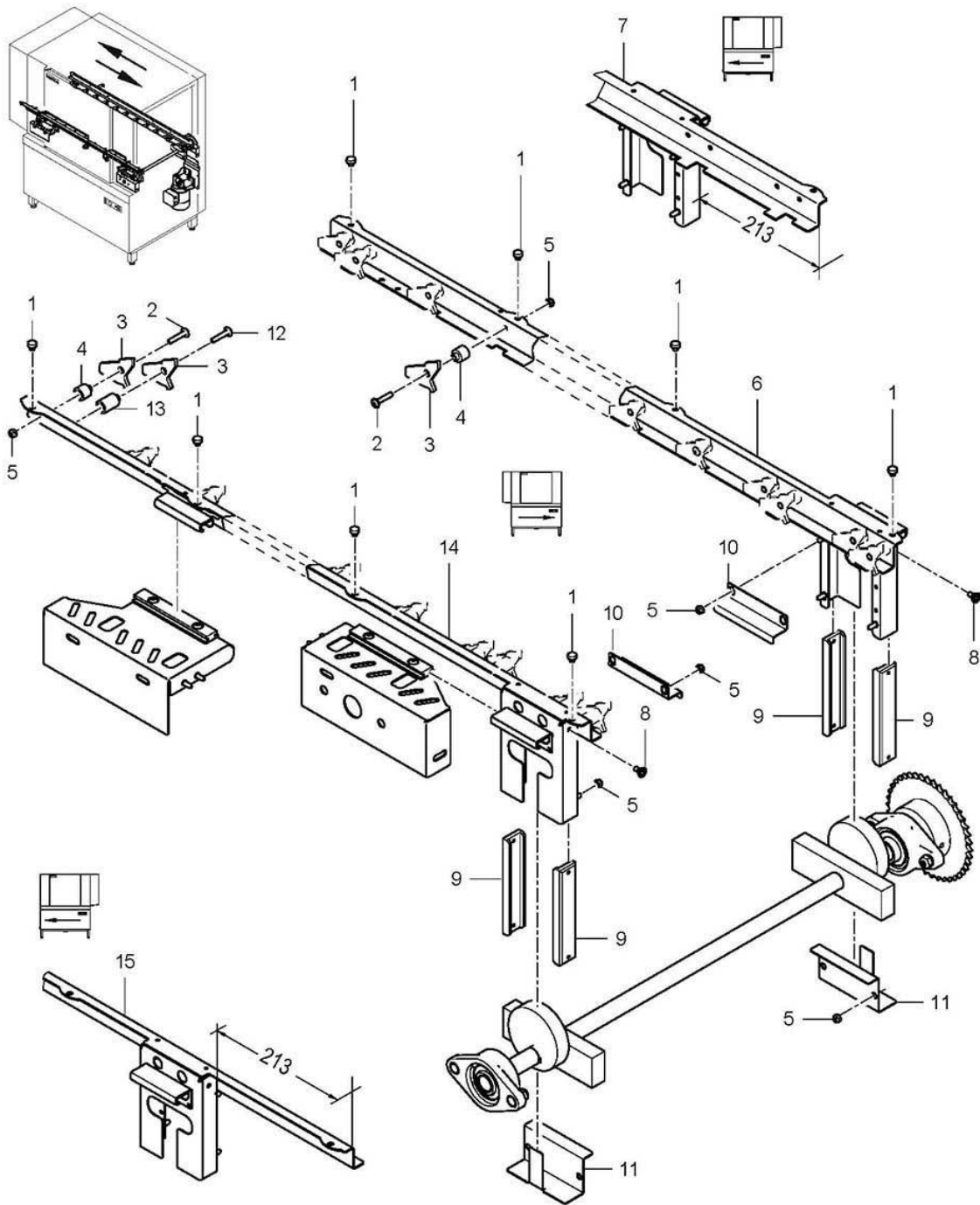

70300673-00

## STR

### Push bars I

Item.	Designation	Parts no.:	Pc.	Notes
1	Bushing; D6,1 X 8,5; D10	70300528	10	
2	Raised head screw with hexagon socket; M5 X 25 MIT FLANSCH	20 10 372	22	
3	Ratchet; 4,0 X 46,37 X 50	70010601	28	
4	Bushing; D8 X 16,5; D15	70300185	22	
5	Hexagonal nut; M5 SELBSTSICHERND	21 05 302		
6	Push bar, rear, L-R	70300533		left - right
6	Push bar, rear R-L	70300580		Optional: for machines 1110 mm (44 inches) in length; left - right
7	Push bar, rear,R-L	70300572		right - left
7	Push bar, rear R-L	70300588		Optional: for machines 1110 mm (44 inches) in length; right - left
8	PT screw; KB 50 X 10	20 17 304	4	
9	Slide rail; 12 X 25 X 129	70006679	4	
10	Z bracket; 1,5 X 46,16 X 92	70300298	2	
11	Support; 1,5 X 92 X 134,5	70300296	2	
12	Raised head screw with hexagon socket; M5 X 35 MIT FLANSCH	20 10 007	6	
13	Bushing; D8 X 25,5; D15	70300535	6	
14	Push bar, front, L-R	70300538		left - right
14	Push bar, front, L-R	70300584		Optional: for machines 1110 mm (44 inches) in length; left - right
15	Push bar, front, R-L	70300576		right - left
15	Push bar, front R-L	70300592		Optional: for machines 1110 mm (44 inches) in length; right - left

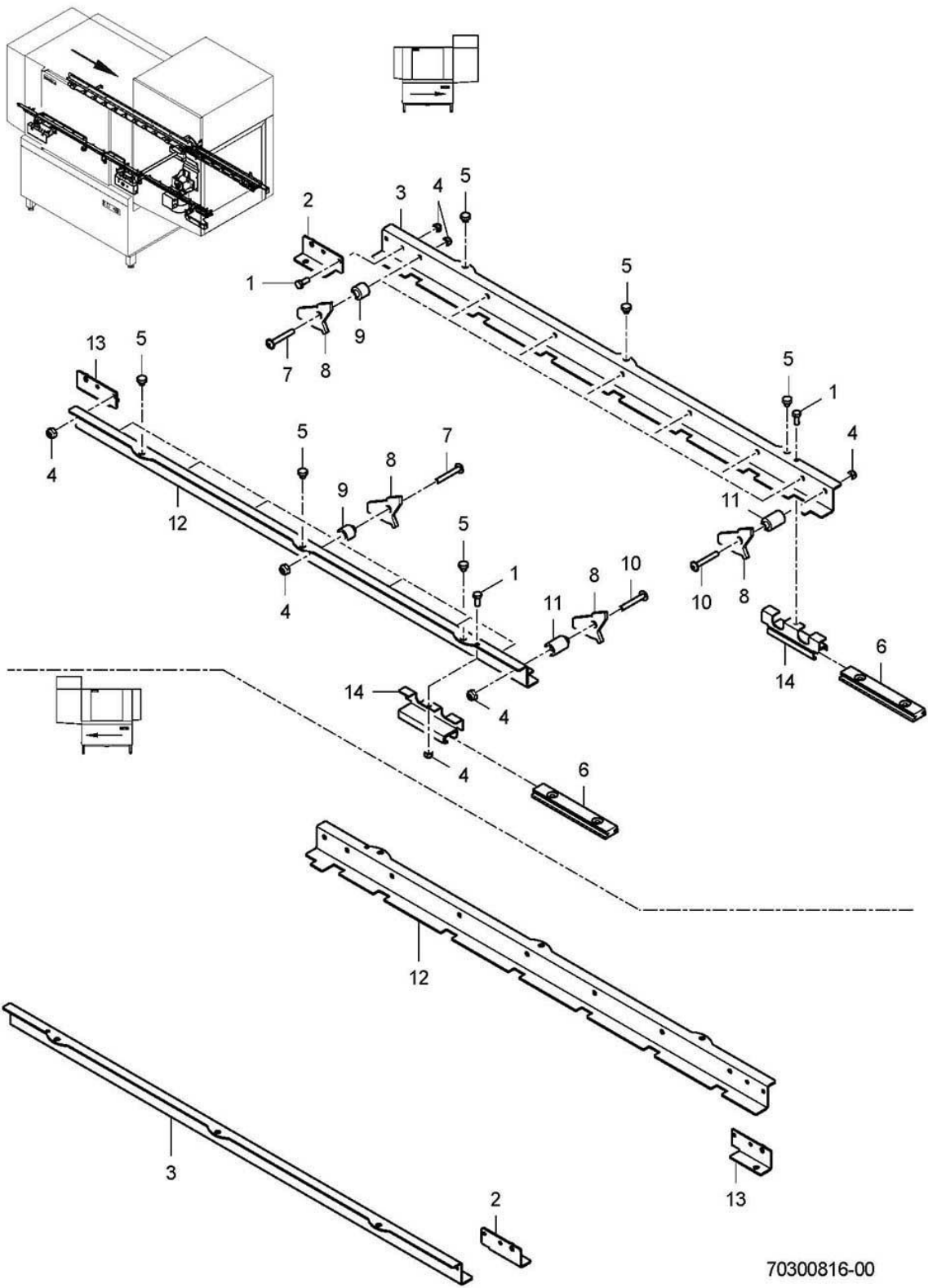

70300816-00

## STR

### Push bars II

Item.	Designation	Parts no.:	Pc.	Notes
1	Hexagon screw, M5 X 12; A70	20 01 323	4	
2	Elbow; 2,0 X 39 X 60	70300707		
3	Push bar; 2,0 X 71,1 X 700	70300703		
4	Hexagonal nut; M5 SELBSTSICHERND	21 05 302		
5	Bushing; D6,1 X 8,5; D10	70300528	6	
6	CF profile; 9 X 20 X 114	70300162	2	
7	Raised head screw with hexagon socket; M5 X 25 MIT FLANSCH	20 10 372	14	
8	Ratchet; 4,0 X 46,37 X 50	70010601	16	
9	Bushing; D8 X 16,5; D15	70300185	14	
10	Raised head screw with hexagon socket; M5 X 35 MIT FLANSCH	20 10 007	2	
11	Bushing; D8 X 25,5; D15	70300535	2	
12	Push bar; 2,0 X 71,1 X 700	70300704		
13	Elbow; 2,0 X 39 X 60	70300715		
14	Elbow	70300174	2	



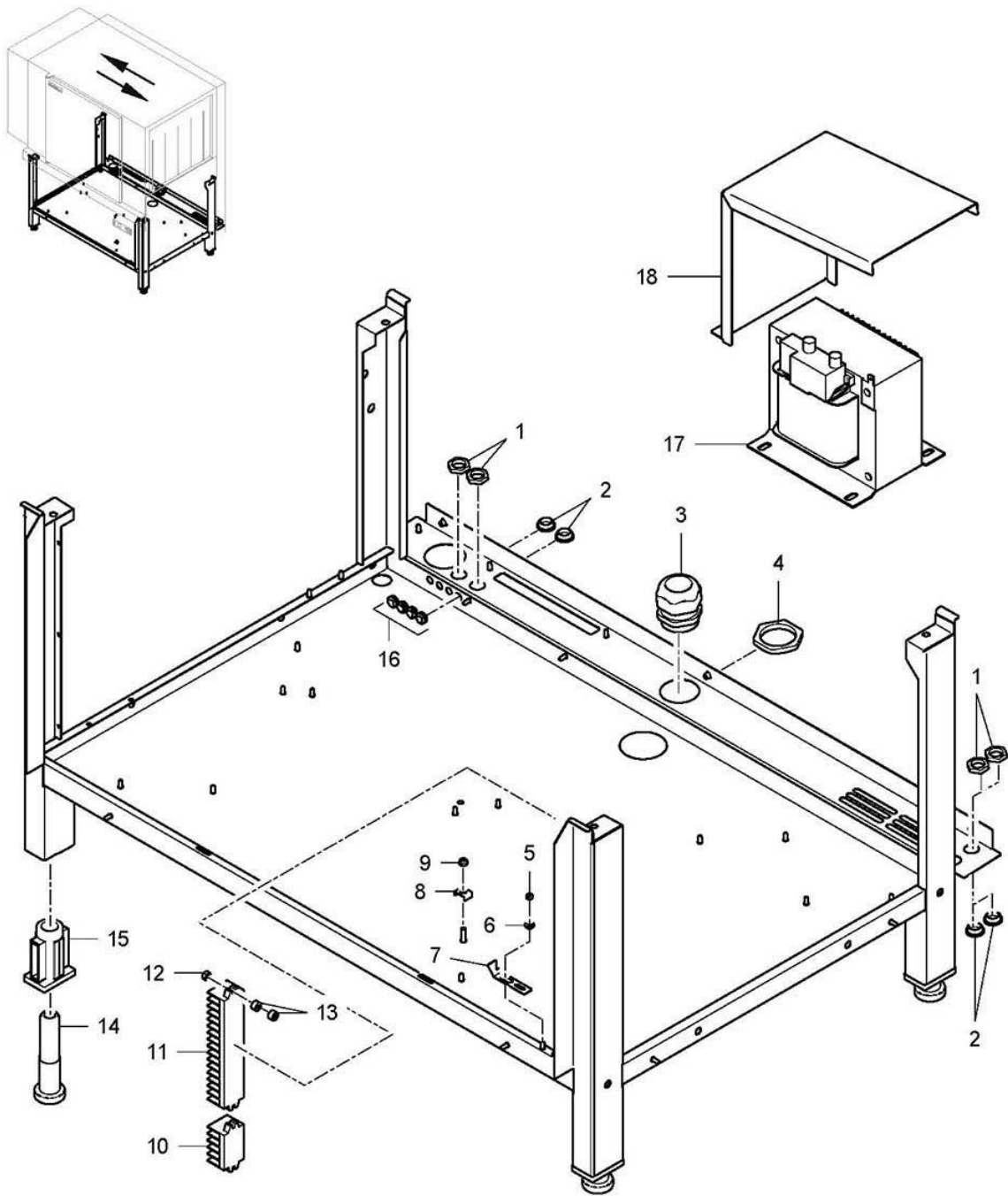

70300668-00

## STR

### Base frame

Item.	Designation	Parts no.:	Pc.	Notes
1	Hexagonal nut; M20 X 1,5 X 5,0; SW27	31 10 162	4	
2	Locking screw; M20 X 1,5	30000139	4	
3	Cable gland; M50 X 1,5;26-35MM;IP68	31 10 156		
3	Cable gland; M63 X 1,5; 34 - 48 MM	31 10 157		
4	Hexagonal nut; M50 X 1,5 X 8,0; SW60	31 10 166		
4	Hexagonal nut; M63 X 1,5 X 8,0; SW75	31 10 167		
5	Hexagonal nut; M5 SELBSTSICHERND	21 05 302	2	
6	Bushing; D8 X 4; D12	70007667		
7	Slide; 1,5 X 24,8 X 80,33	70300520		
8	Clamp strap; 1,8 X 14 X 26,07	31 09 095		
9	Hexagonal nut; M6	21 01 304		
10	Terminal strip; 5-POLIG	31 09 254		
11	Terminal strip; 16-POLIG	31 09 154		
12	Hexagonal nut; M4 SELBSTSICHERND	21 05 300	4	
13	Spacer; D5,3 X D12 X 7	22 08 513	8	
14	Foot cleats; RD26 X 1/8; SW40 X 135	61004786	4	
15	Threaded insert; RD26 X 1/8;39 X 59 X85	61004787	4	
16	Hose nozzle; 6,25 X D15; D8,5	61004890	4	
17	800 VA transformer or housing; 150 X 130 X 165 (LBH)	31 15 031		Option
18	Cover plate; 1,25 X 174,4 X 410,86	70300646		Option

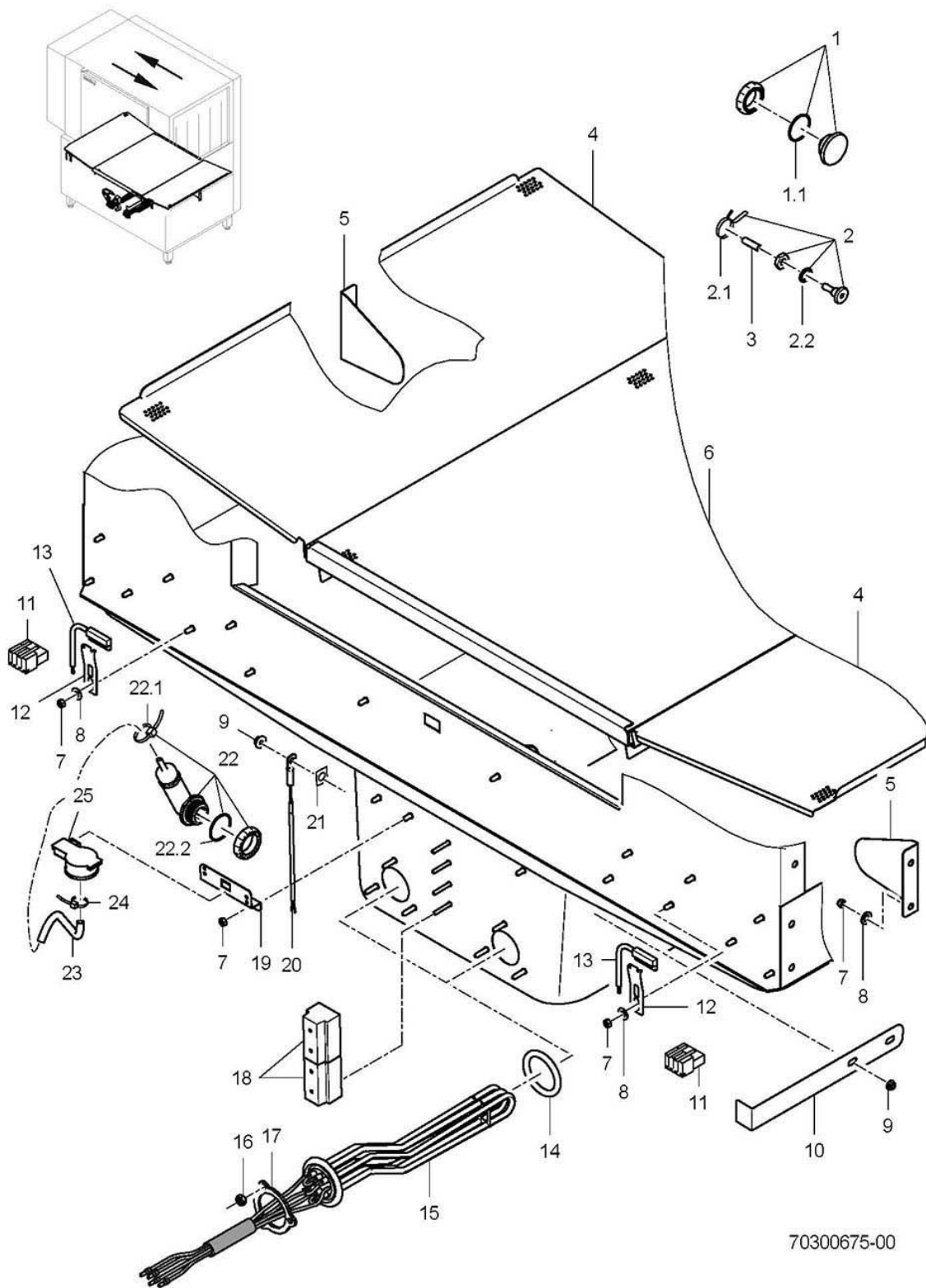

70300675-00

## STR

### Housing

Item.	Designation	Parts no.:	Pc.	Notes
1	Dummy plug; G 3/8" X 21,4; SW10;	70004899		incl. item 1.1
1.1	O-ring; 16 X 2,5	27 07 001		
2	Dosing nipple set; M10 X 29; SW5	61005883		incl. item 2.1 - 2.2
2.1	Wire hose clamp; D8,6 X 1	28 02 348		
2.2	O-ring; 10 X 2,5	27 07 030		
3	End cap; D5,7 X 25,4	35 06 180		
4	Filter support; 1,25 X 370,44 X 684,2	70300109	2	
5	Bracket; 1,25 X 91 X 122,35	70300260	2	
6	Strainer; 1,20 X 583,03 X 752	70005926		
7	Hexagonal nut; M5 SELBSTSICHERND	21 05 302		
8	Washer; D5,3 X D15 X 1,2	22 05 301		
9	Ratchet nut; M5	21 01 310		
10	Elbow; 0,8 X 30 X 263,25	70300522		
11	Macro-module plug; RAST5; 2-POLIG; UNCOD.	31 12 091		
12	Holder; 0,8 X 19 X 65	70007658		
13	Solenoid switch; 32 X 14,9 X 6,9;1350MM	31 24 272		
14	O-ring; 43 X 7,0	27 07 088	2	
15	5.0 kW heating element with fuse; 3 X 400V	31 03 169	2	
15	5.0 kW heating element with fuse; 3 X 420V	31 03 170	2	
15	5.0 kW heating element with fuse; 3 X 420V	31 03 240	2	Australia
15	5.0 kW heating element with fuse; 3 X 200V	31 03 167	2	
15	5.0 kW heating element with fuse; 3 X 230V	31 03 168	2	
15	5.0 kW heating element with fuse; 3 X 440V	31 03 171	2	
16	Hexagonal nut; M5	21 01 203	6	
17	Locking washer; D43 X D80 X 4,0	01 17 003	2	
18	Appliance terminal G10/4; 4-POLIG; 10QMM	31 09 227		
19	Plug block holder; 1,25 X 47,45 X 80	70007315		
20	Thermal sensor kit 1700mm	80003804		
21	Heat conducting foil with hole; 0,25 X 12 X 15	61005285		
22	Air chamber set	60003525		incl. item 22.1 - 22.2
22.1	Cable tie; 100 X 2,5	31 20 175		
22.2	O-ring	30000196		
23	Hose; DN5 X 1,5	40 01 024		180 mm; "By-the-metre" goods
24	Cable tie; 100 X 2,5	31 20 175		
25	Pressure transmitter; 0-30MBAR;5VDC/0,5-3,5V	31 26 044		
o.P.	Pressure transmitter cable; 3 X 0,34QMM	70300408		

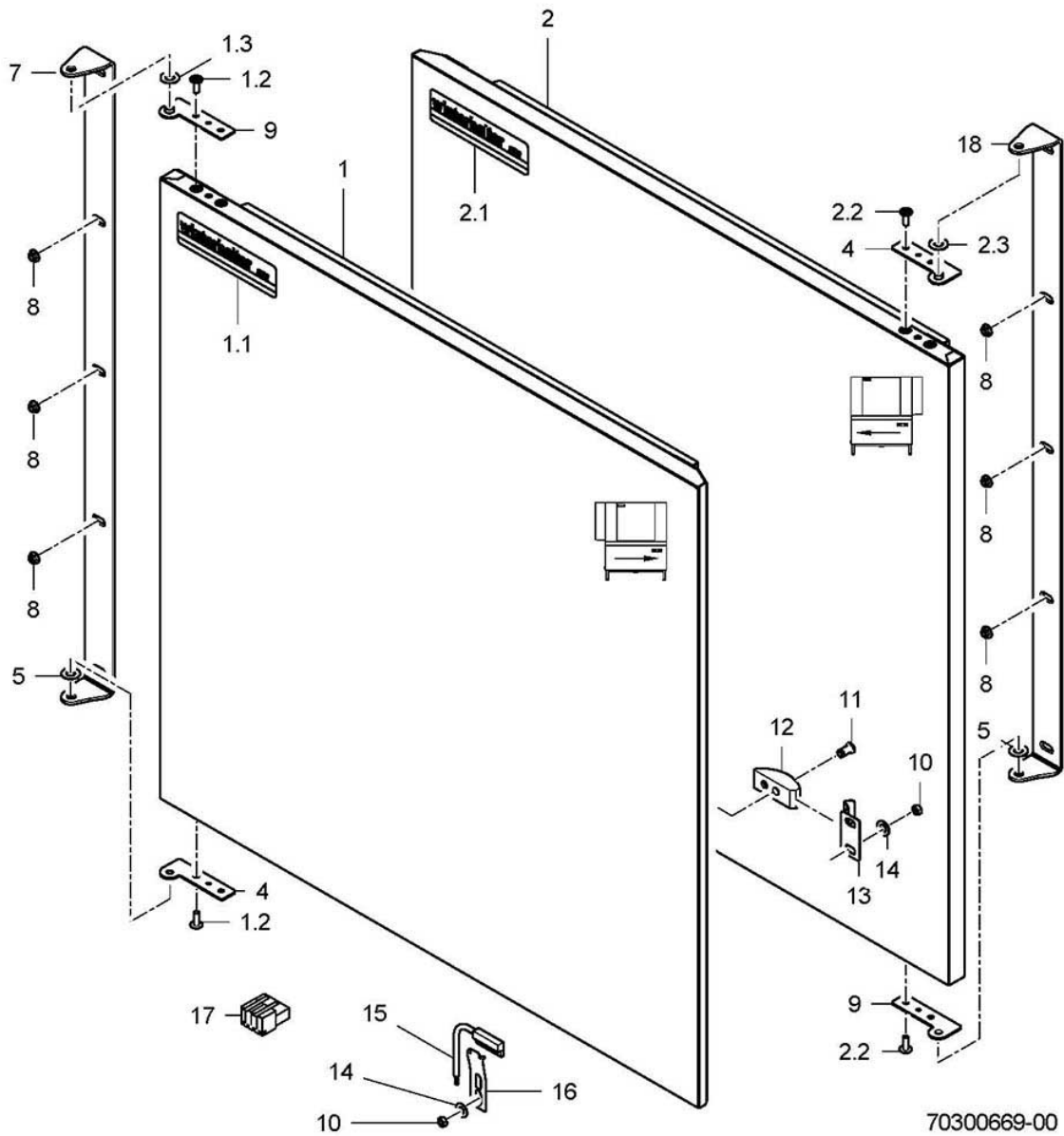
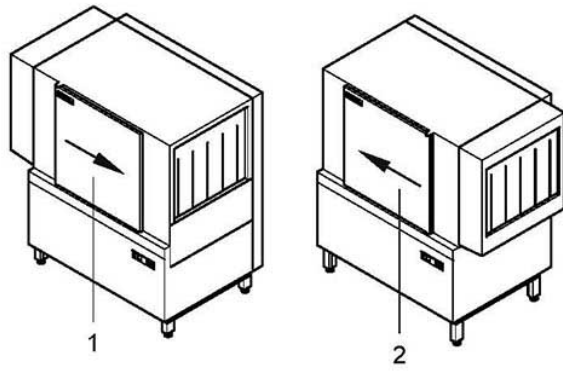

70300669-00

## STR

### Door

Item.	Designation	Parts no.:	Pc.	Notes
1	Door L-R	70300687		incl. item 1.1 – 1.3
1.1	"Winterhalter STR" sign; 0,175 X 35 X 126	70300566		
1.2	Raised head screw with hexagon socket; M5 X 16 MIT FLANSCH	20 10 307	4	
1.3	Washer; D8,5 X D17 X 1,0	22 08 515	2	
2	Door R-L	70300688		incl. item 2.1 – 2.3
2.1	"Winterhalter STR" sign; 0,175 X 35 X 126	70300566		
2.2	Raised head screw with hexagon socket; M5 X 16 MIT FLANSCH	20 10 307	4	
2.3	Washer; D8,5 X D17 X 1,0	22 08 515	2	
4	Hinge	70006274		
7	Hinge L-R; 3,0 X 35 X 791,9	70300710		
8	Ratchet nut; M6	21 01 311	3	
9	Hinge	70006271		
10	Hexagonal nut; M5 SELBSTSICHERND	21 05 302	2	
11	Nut; M5; D11 X D7 X 15; SW3	65005474		
12	Door latch; 16,2 X 20 X 50	70300253		
13	Snapper; 1,0 X 45 X 61,26	70300254		
14	Washer; D5,3 X D15 X 1,2	22 05 301	2	
15	Solenoid switch; 32 X 14,9 X 6,9;1350MM	31 24 272		
16	Holder; 0,8 X 19 X 65	70007658		
17	Macro-module plug; RAST2,5;3-POLIG UNCOD.	31 12 095		
18	Hinge R-L; 3,0 X 35 X 791,9	70300711		

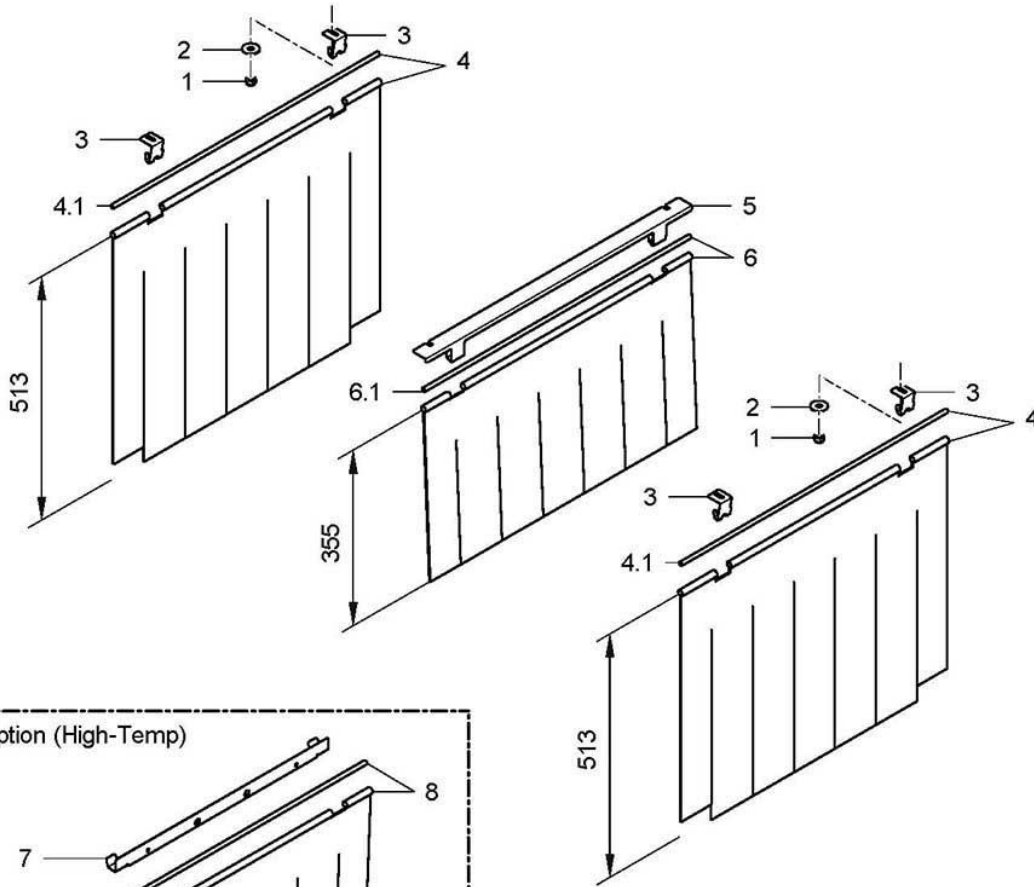
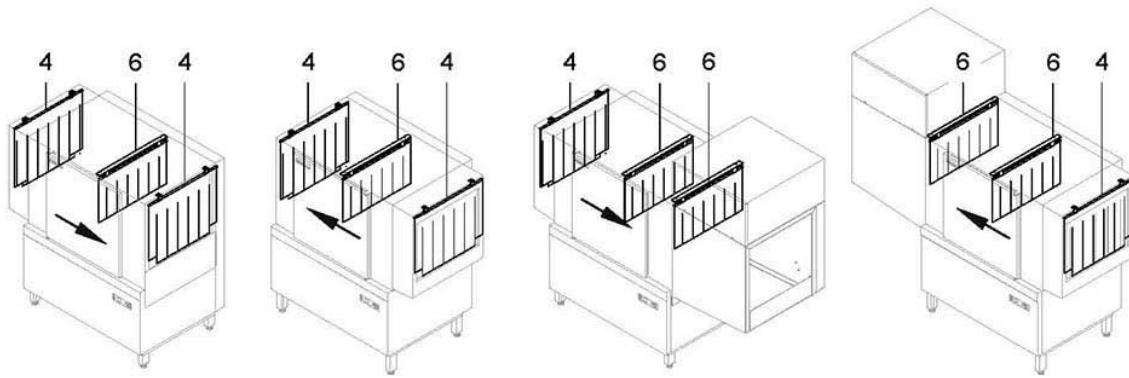

70300671-00

## STR

### Curtains

Item.	Designation	Parts no.:	Pc.	Notes
1	Hexagonal nut; M5 SELBSTSICHERND	21 05 302		
2	Washer; D5,3 X D15 X 1,2	22 05 301		
3	Retainer; 1,5 X 54,65 X 89,15	70300519		
4	Curtain; 513 X 646 (0.63 INCH)	70007240		incl. item 4.1
4.1	Round material; D8 X 646	70007241		
5	Curtain rail; 1,5 X 92,2 X 646	70300283		
6	Curtain; 355 X 646 (0.63 INCH)	70008044		incl. item 6.1
6.1	Round material; D8 X 646	70007241		
7	Retainer; 1,5 X 56,53 X 516	70300596		
8	Curtain; 355 X 646 (0.63 INCH)	70008044		High-Temp
8.1	Round material; D8 X 646	70007241		



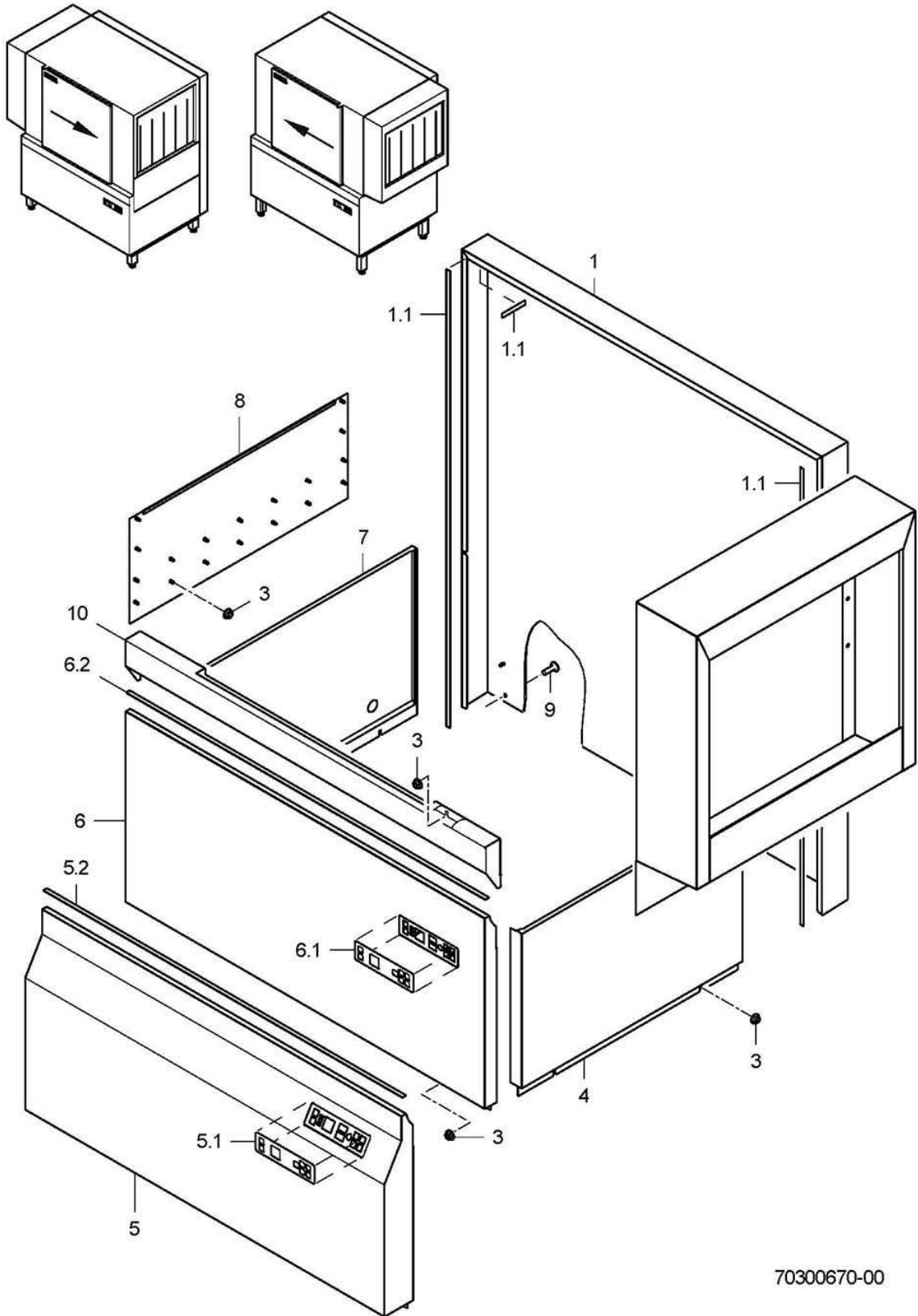

70300670-00

## STR

### Panelling

Item.	Designation	Parts no.:	Pc.	Notes
1	Rear wall covering	70300689		incl. item 1.1
1.1	Adhesive tape; 9 BREIT;2 DICK X 10000	48 03 022		1 roll = 10 m
3	Ratchet nut; M5	21 01 310		
4	Housing panel right	70300116		
5	Housing panel, front steam	70300617		incl. item 5.1 – 5.2
5.1	"STR operating panel" plate; 0,175 X 50 X 180	31 24 280		
5.2	Adhesive tape; 9 BREIT;2 DICK X 10000	48 03 022		1 roll = 10 m
6	Housing panel, front	70300618		incl. item 6.1 - 6.2
6.1	"STR operating panel" plate; 0,175 X 50 X 180	31 24 280		
6.2	Adhesive tape; 9 BREIT;2 DICK X 10000	48 03 022		1 roll = 10 m
7	Housing panel left	70300119		
8	End plate	70300118		installed on the left-hand or right-hand side
9	Raised head screw with hexagon socket; M5 X 16 MIT FLANSCH	20 10 307	3	
10	Water channel	70300089		

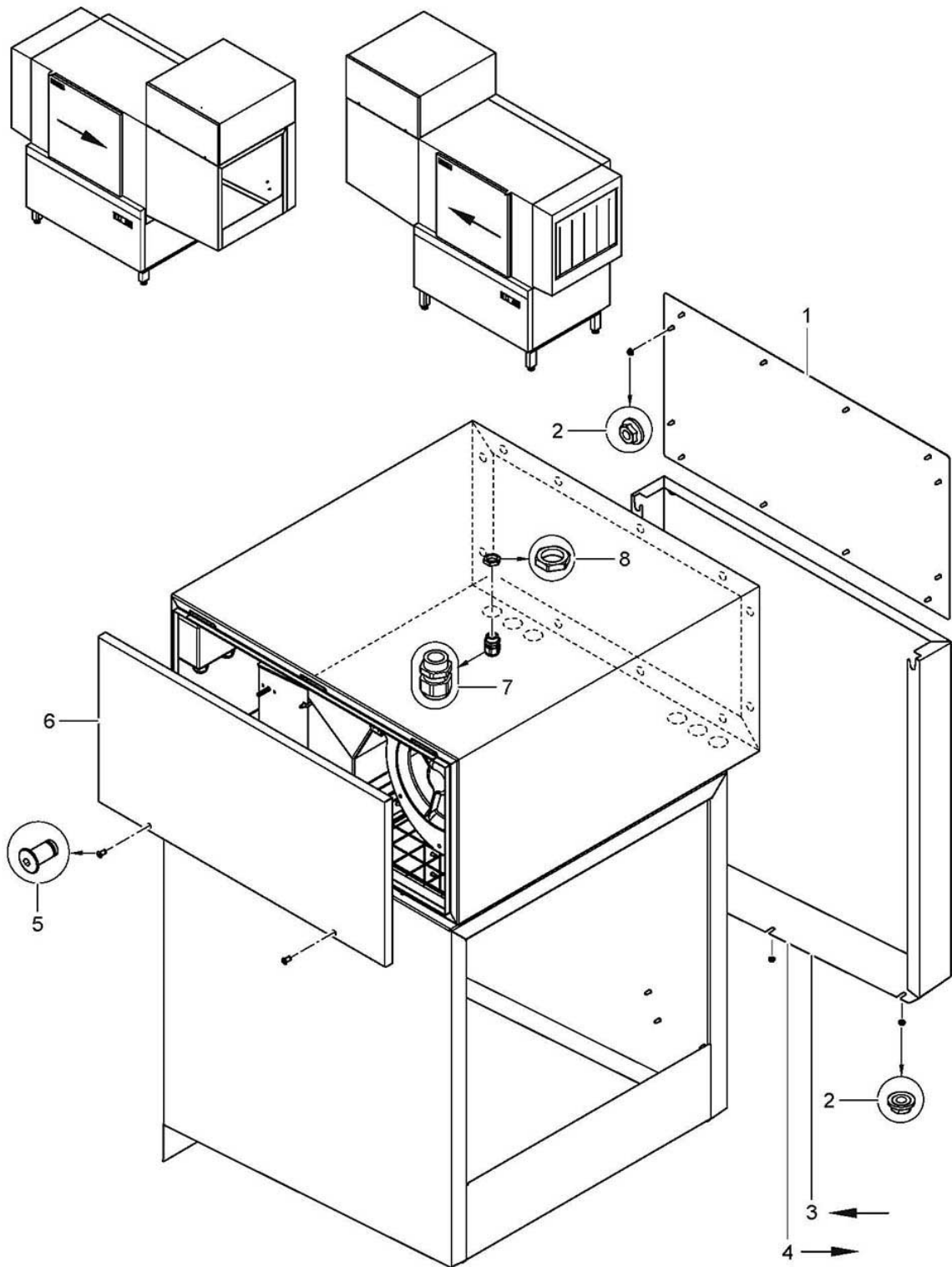

70300814-00

## STR

### Panelling

Item.	Designation	Parts no.:	Pc.	Notes
1	Cover	70300698		
2	Ratchet nut; M5	21 01 310		
3	Rear wall panelling R-L	70300755		right - left
4	Rear wall panelling L-R	70300752		left - right
5	Nut; M5; D11 X D7 X 15; SW3	65005474	2	
6	Cover	70008509		
7	Cable gland; M20 X 1,5; 6-13MM; IP68	31 10 152		
8	Hexagonal nut; M20 X 1,5 X 5,0; SW27	31 10 162		

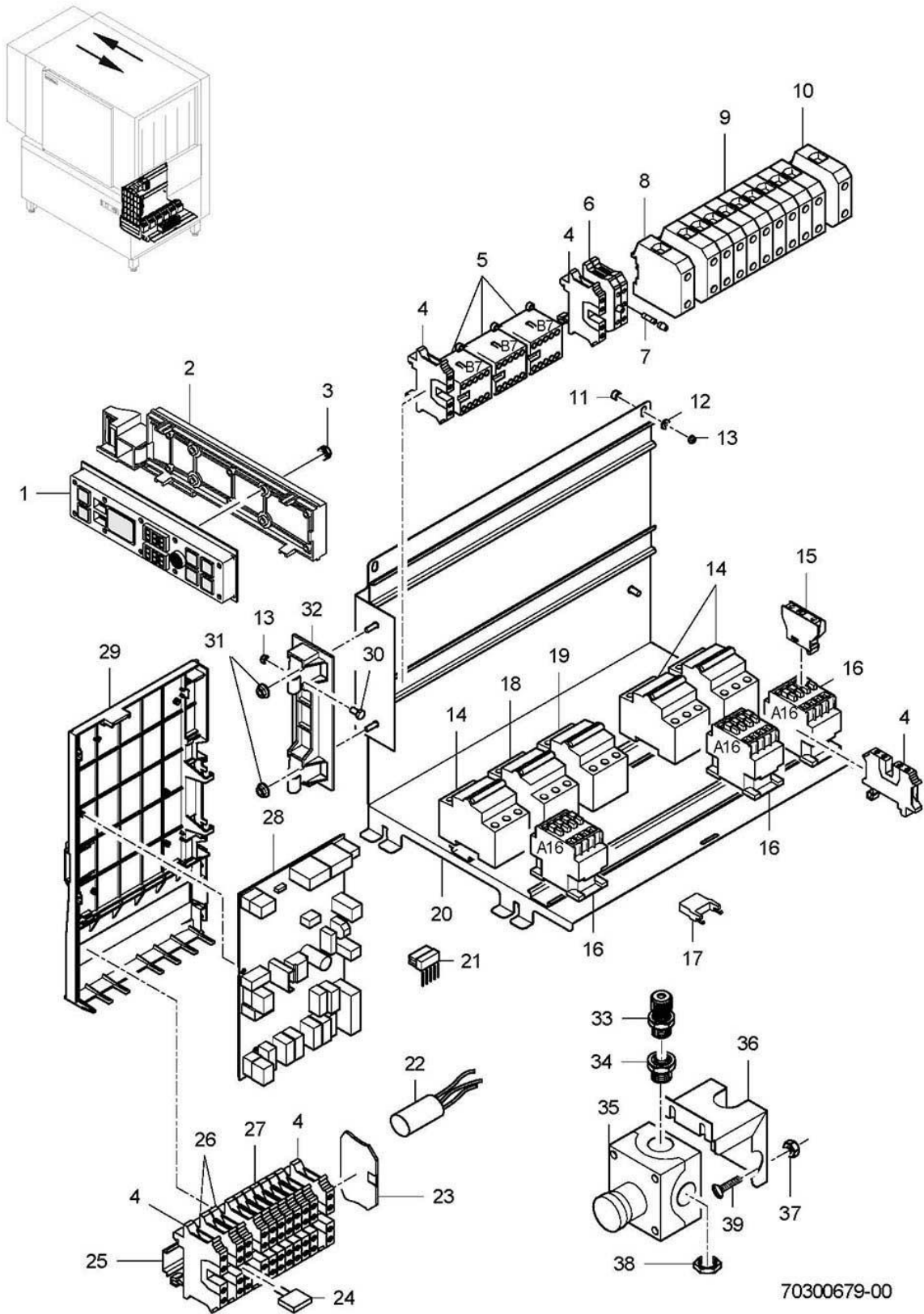

70300679-00

## STR

### Electric parts

Item.	Designation	Parts no.:	Pc.	Notes
1	Operating panel; 25 X 55 X 210	31 24 222		
2	Support for operating panel	60003350		
3	Nut-and-washer assembly; M3	21 01 312	4	
4	UT 4-Quattro, potenial earth, double terminal; GRÜN/GELB	31 09 272		
5	Contactora B7:3H 1 N/C contact; 220-255V/50-60HZ	31 04 154		
5	Contactora B7:3H 1 N/C contact; 200V/50-60HZ	31 04 171		Japan
6	Fuse terminal; 10 A	31 09 149	2	
7	Fine fuse, medium time lag; 250V; 4,0A; 5 X 20	31 11 123	2	
8	Universal terminal block, UK 35, blue	31 09 173		
9	Universal terminal block, grey; UK 35	31 09 172		triangle switched, heated electrically
9	High current terminal block UKH 50	31 09 280		star switched, heated electrically
9	Universal terminal block, grey; UK 35	31 09 172		steam heated
10	Protective conductor terminal USLKG 35	31 09 174		triangle switched, heated electrically
10	Protective conductor terminal USLKG 50	31 09 284		star switched, heated electrically
10	Protective conductor terminal USLKG 35	31 09 174		steam heated
11	Spacer; D5,3 X D12 X 7	22 08 513	2	
12	Washer; D5,3 X D12 X 0,8	22 02 313		
13	Hexagonal nut; M5 SELBSTSICHERND	21 05 302		
14	Circuit breaker; 3-POLIG; 25A-C	31 11 311		
15	Auxiliary switch, 1 N/O contact	31 04 166		
16	Contactora A16:3S: 1 N/C contact; 230V/50-60HZ; 7,5KW	31 04 162		
16	Contactora A16:3S: 1 N/C contact; 200V/50-60HZ; 7,5KW	31 04 163		Japan
17	RC element; 250V	31 13 166		
18	Circuit breaker; 3-POLIG, 16A-K	31 11 316		
19	Circuit breaker; 3-POLIG; 6A-K	31 11 317		
20	Mounting plate	70300380		
21	Bus cable set	65005466		
22	Radio interference suppression capacitor; 0,27MF + 2 X 27000PF	31 13 078		
23	Cover; D-UT 2,5/4-QUATTRO	31 09 279		
24	Fixed bridge; 2-POLIG; FBS 2-6	31 09 276		
25	Snap-on rail; 1,0 X 35 X 185	60003244		
26	Blue UT 4-Quattro, double terminal; BLAU	31 09 271		
27	UT 4-Quattro double terminal; GRAU	31 09 270		
28	STR program control	70300599		
29	Assembly plate	60003660		
30	Hexagon screw, M5 X 10; A70	20 01 300		
31	Ratchet nut; M5	21 01 310		
32	Hinge	70300139		
33	PG9 cable gland; PG9; 4-8 MM; IP68	31 10 042		
34	Reducing ring; M20 X 1,5/M16 X 1,5	31 10 178		
35	"Emergency stop" button	31 24 244		
36	Holder for Emergency Stop; 1,5 X 112 X 178	70005621		
37	Hexagonal nut; M4 SELBSTSICHERND	21 05 300		
38	Hexagonal nut; M20 X 1,5 X 5,0; SW27	31 10 162		
39	Countersunk screw, M4 X 12	20 10 312		

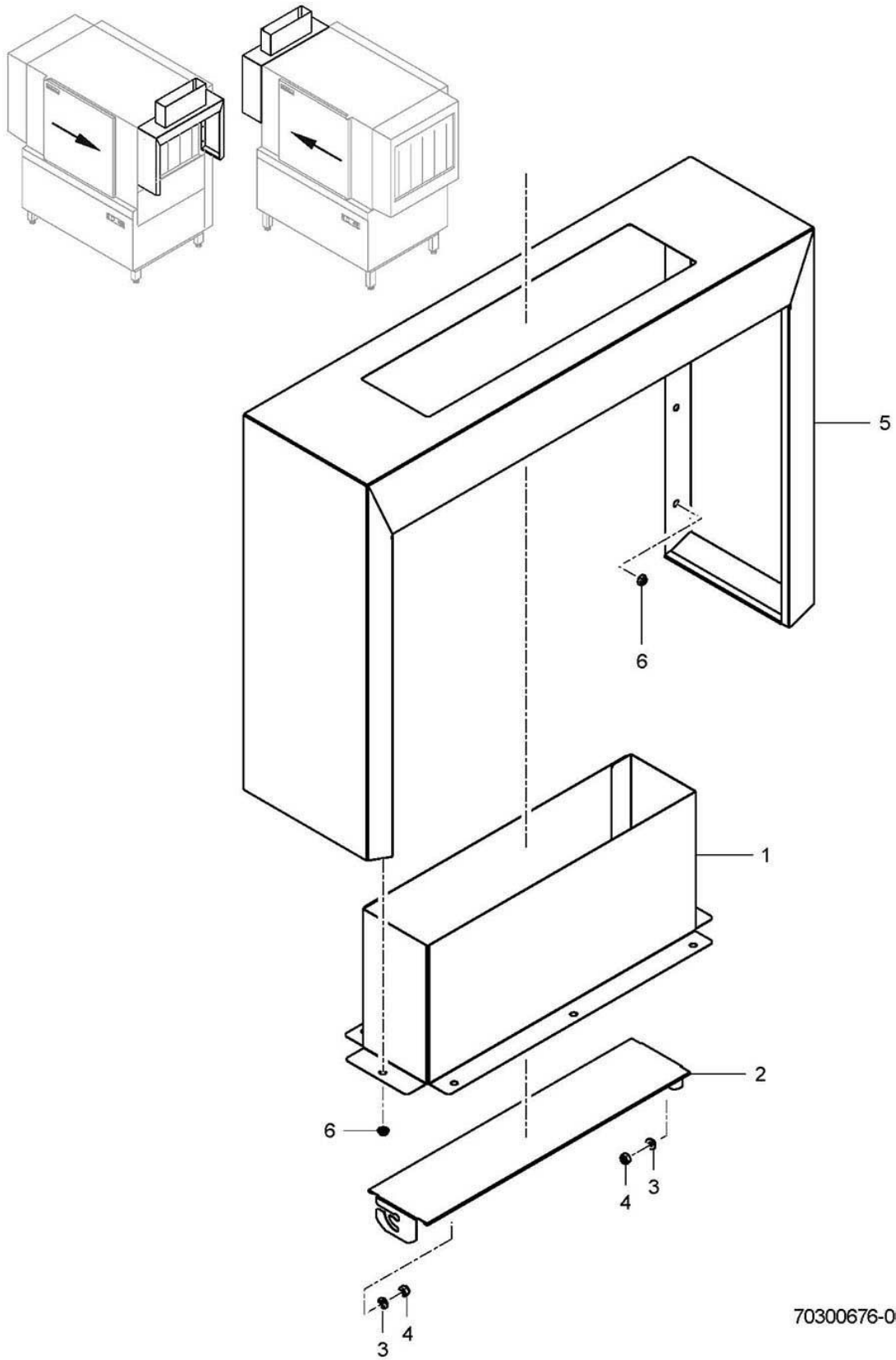

70300676-00

## STR

### Vapour extraction

Item.	Designation	Parts no.:	Pc.	Notes
1	Vapour extraction connecting piece	70300145		
2	Shutter; 1,25 X 102,6 X 472,2	70300148		
3	Bushing; D8 X 4; D12	70007667		
4	Hexagonal nut; M5 SELBSTSICHERND	21 05 302		
5	Frame	70300327		
6	Ratchet nut; M5	21 01 310		



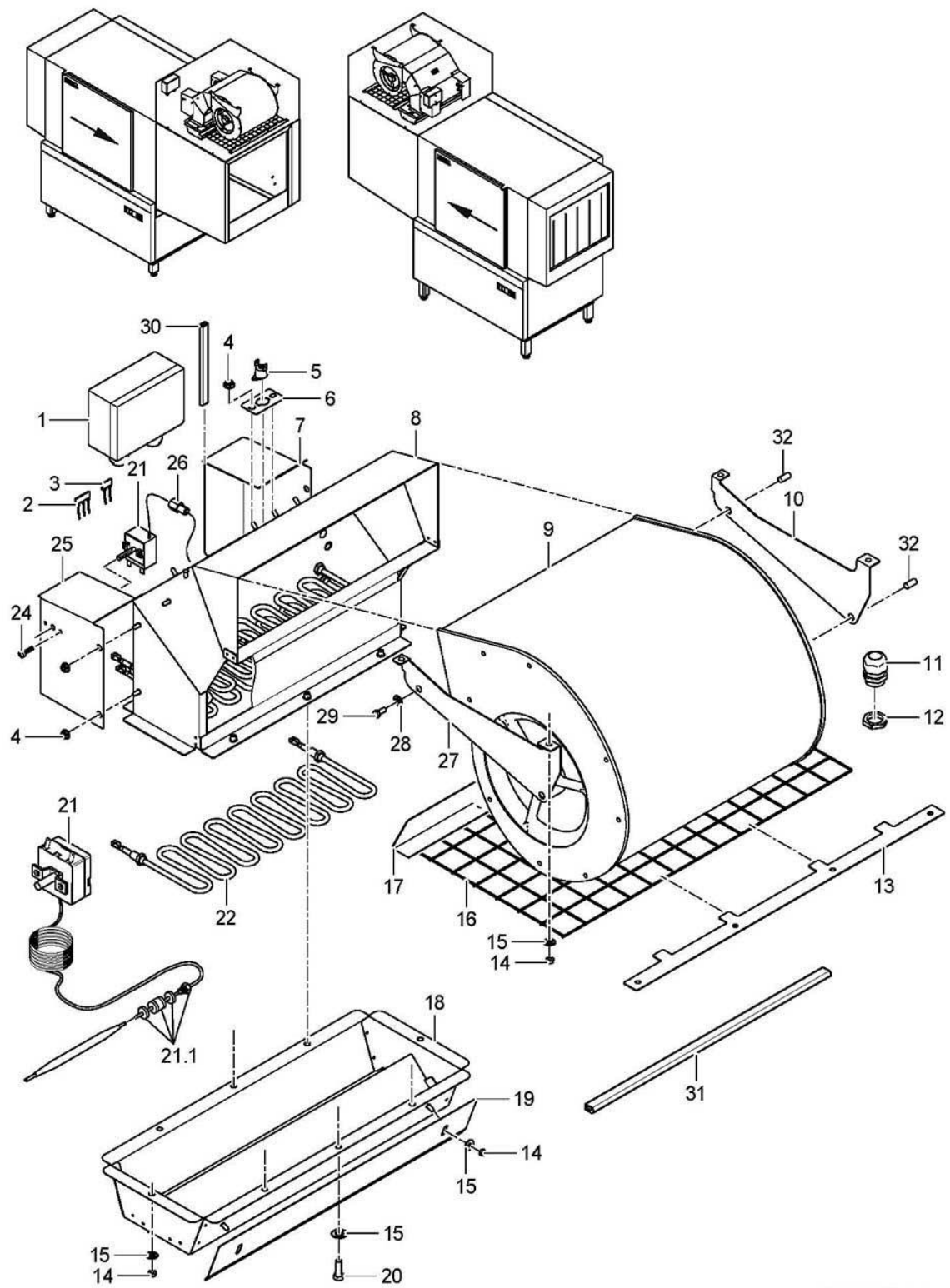

70300813-00

## STR

### Blower

Item.	Designation	Parts no.:	Pc.	Notes
1	15-pos. terminal block box; 130 X 94 X 57; IP 66	31 18 097		
2	Insertion bridge; 3-POL.;VOLLISO.;EB 3-6	31 09 214		
3	Insertion bridge; 2-POL.;VOLLISO.;EB 2-6	31 09 263		
4	Ratchet nut; M5	21 01 310	2	
5	Safety thermostat, man. back; 100°C/+ -4°C/ 250V AC	31 25 054		
5	Safety thermostat, man. Back; 120°C/+ -4°C/ 250V AC	31 25 063		High-Temp
6	Holder; 1,0 X 30 X 55	70008390		
7	Guard plate	70300744		
8	Connecting sleeve	70008106		
9	0.42 kW radial blower; 230/400V+-10%; 50/60HZ	31 17 027		
9	0.42 kW radial blower; 200/345V+-10%; 50/60HZ	31 17 028		Japan
10	Elbow; 1,5 X 126,83 X 300	70009342		
11	Cable gland; M20 X 1,5; 6-13MM;IP68	31 10 152		
12	Hexagonal nut; M20 X 1,5 X 5,0; SW27	31 10 162		
13	Clamping plate; 1,25 X 42 X 585	70300734		
14	Hexagonal nut; M5 SELBSTSICHERND	21 05 302		
15	Washer; D5,3 X D15 X 1,2	22 05 301		
16	Wire fence; D2 X 296 X 548	70010169		
17	Clamping plate	70300737		
18	Jet	70009300		
19	Shutter; 0,8 X 75,18 X 490	70010416		
20	Hexagon screw; M5 X 12; A70	20 01 323	6	
21	Thermostat; 1750 LG; 220V	31 25 013		
21.1	Gland screwing	31 25 012		
22	2.0 kW corrugated heating element; 400V/1	31 03 236	3	400V/3
22	2.0 kW corrugated heating element; 415V/1	31 03 237	3	420V/3
22	2.0 kW corrugated heating element; 230V/1	31 03 137	3	3x230V
22	2.0 kW corrugated heating element; 200V/1	31 03 136	3	200V/3
22	2.0 kW corrugated heating element; 440V/1	31 03 238	3	440V/3
24	Countersunk screw; M4 X 8	20 10 309	2	
25	Guard plate	70300740		
26	Bush for thermostat; M10 X 1; SW13	70300741		
27	Elbow; 1,5 X 126,83 X 300	70009341		
28	Washer; D6,4 X D18 X 1,6	22 05 302	2	
29	Hexagon screw; M6 X 16; A70	20 01 306	2	
30	Edge protection; 5,5 X 8,0 X 320	60002260		
31	Sealing profile; 1,0 - 2,0MM	40 04 006		4000 mm; "By-the-metre" goods
32	Grub screw; M6 X 16	20 30 302	2	

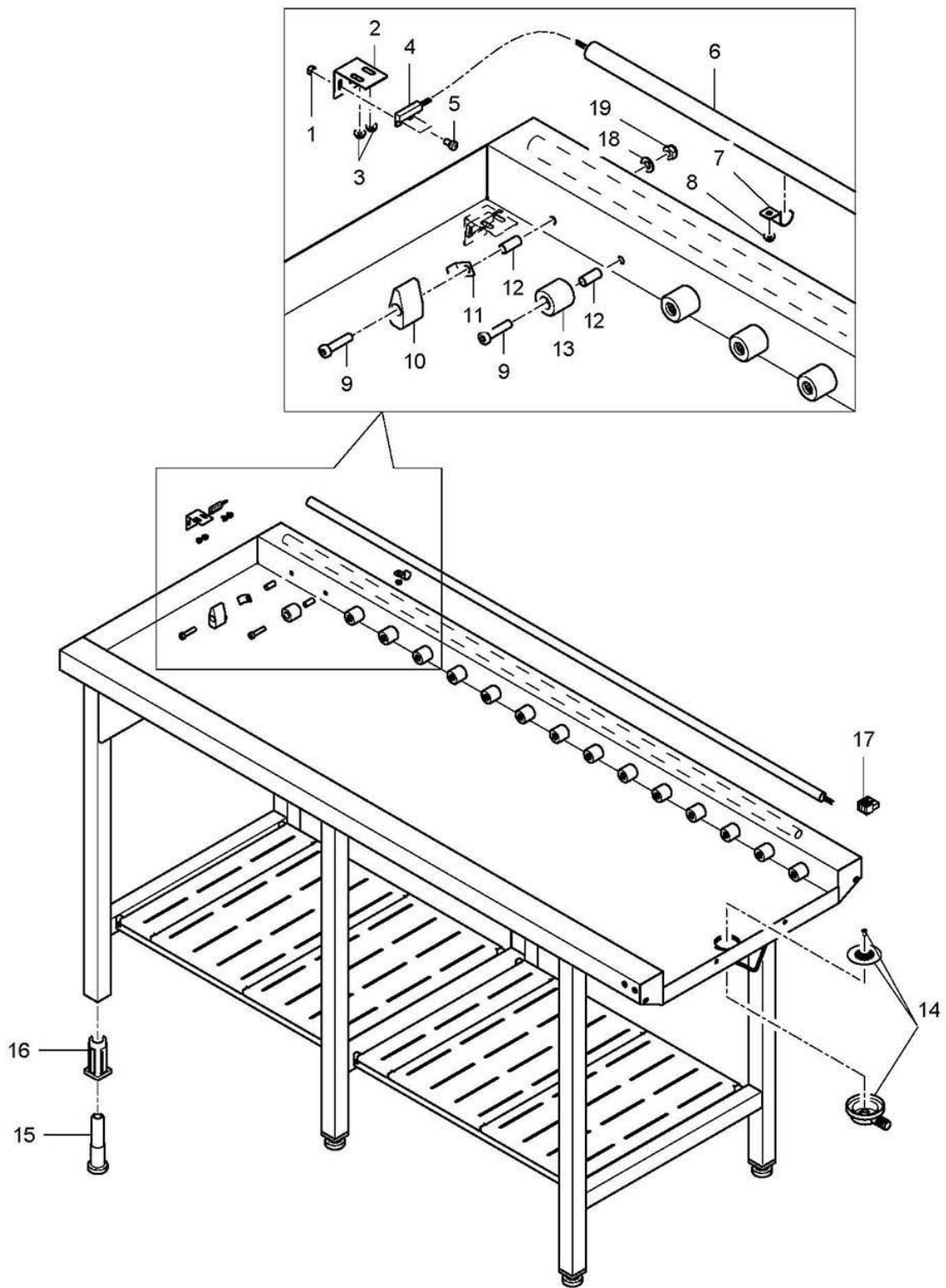

70300677-00

## STR

### Stub roller tabling

Item.	Designation	Parts no.:	Pc.	Notes
1	Hexagonal nut; M3 SELBSTSICHERND	21 05 303	2	
2	Retaining bracket; 1,25 X 32 X 79,8	75203761		
3	Ratchet nut; M5	21 01 310	2	
4	Solenoid switch; 32 X 14,9 X 6,9;7000LG	31 24 276		
5	Raised head screw; M3 X 10	20 10 004	2	
6	Insulating tube; PG13,5	31 14 090		
7	Bracket; 1,5 X 15 X 57	55 25 017	2	
8	Ratchet nut; M5	21 01 310	2	
9	Cylinder head screw; M8 X 35; 8.8	20 03 306		
10	Selector paddle	75203760		
11	Bracket; 1,0 X 15 X 34,9	75203763		
12	Pipe; D10 X 0,75 X 22,5	75200788		
13	Roller; DN30 X 29	75200593		
14	Drain valve; 2 3/4" X 1"(2,5CM)	29 04 281		
15	Foot cleats; RD26 X 1/8; SW40 X 135	61004786		
16	Threaded insert; RD26 X 1/8; 40 X 40 X85	61004785		
17	Macro-module plug; RAST2,5;3-POLIG UNCOD.	31 12 095		
18	Washer; D8,4 X D17 X 1,6	22 01 303		
19	Hexagonal nut; M8 SELBSTSICHERND	21 05 306		

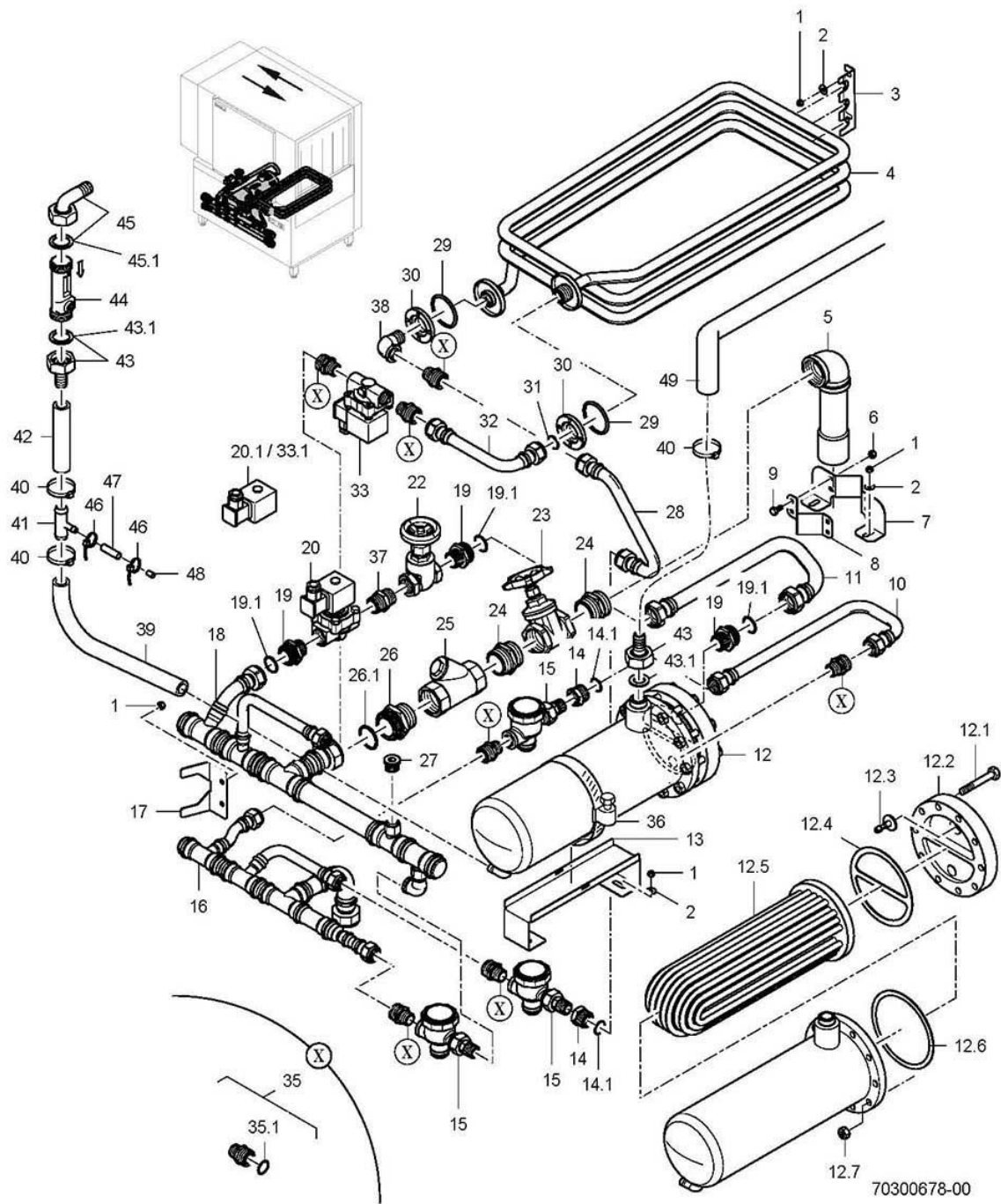

70300678-00

## STR

### Steam heating

Item.	Designation	Parts no.:	Pc.	Notes
1	Hexagonal nut; M5 SELBSTSICHERND	21 05 302		
2	Washer; D5,3 X D15 X 1,2	22 05 301		
3	Support bracket; 1,5 X 53,3 X 113	70009689		
4	Steam coil	70009613		
5	Steam pipe elbow	70009918		
6	Hexagonal nut; M6 SELBSTSICHERND	21 05 304	4	
7	Pipe support; 1,5 X 88,33 X 181,62	70009786		
8	Clamp; 1,5 X 40 X 121,62	70009770		
9	Hex bolt; M6 X 12; A70	20 01 321	4	
10	Condensate drain elbow	70009765		
11	Boiler pipe elbow	70009763		
12	Counterflow heat exchanger	70009590		incl. item 12.1 - 12.7
12.1				
12.2	Connection flange	70009593		
12.3	Cascade orifice	70009948		
12.4	Gasket	70009768		
12.5	Calorifier tube nest	70009594		
12.6	Gasket	70009759		
12.7	Hexagonal nut; M10	21 01 306	10	
13	Boiler ; 1,5 X 81,66 X 428,31	70009685		
14	Reducing nipple; G 1/2" X G 3/4"; SW27	70300681		incl. item 14.1
14.1	O-ring; 18 X 2,5 (18,2 X 2,6)	27 07 077		
15	Rapid condensate drain; R 1/2"	29 03 002		
16	Condensate drain pipe	70300455		
17	Pipe support; 1,5 X 92,5 X 96,5	70009895		
18	Steam distributor pipe	70300458		
19	Double nipple; G 1" X R 3/4"; SW36	70300682		incl. item 19.1
19.1	O-ring; 22,2 X 3,1	27 07 089		
20	2/2-Way solenoid valve; G3/4";230-240V;50-60HZ	31 06 167		incl. item 20.1
20.1	Coil; 220V/50HZ	31 06 147		
20	2/2-Way solenoid valve; R3/4"; 220-230V; 60HZ	31 06 240		incl. item 20.1
20.1	Coil; 220V/60HZ	31 06 149		
20	2/2-Way solenoid valve; R3/4"; 200V; 50HZ	31 06 241		incl. item 20.1
20.1	Coil; 200V/50HZ	31 06 156		
20	2/2-Way solenoid valve; R3/4"; 200V; 60HZ	31 06 242		incl. item 20.1
20.1	Coil; 200V/60HZ	31 06 157		

For missing items, see next page

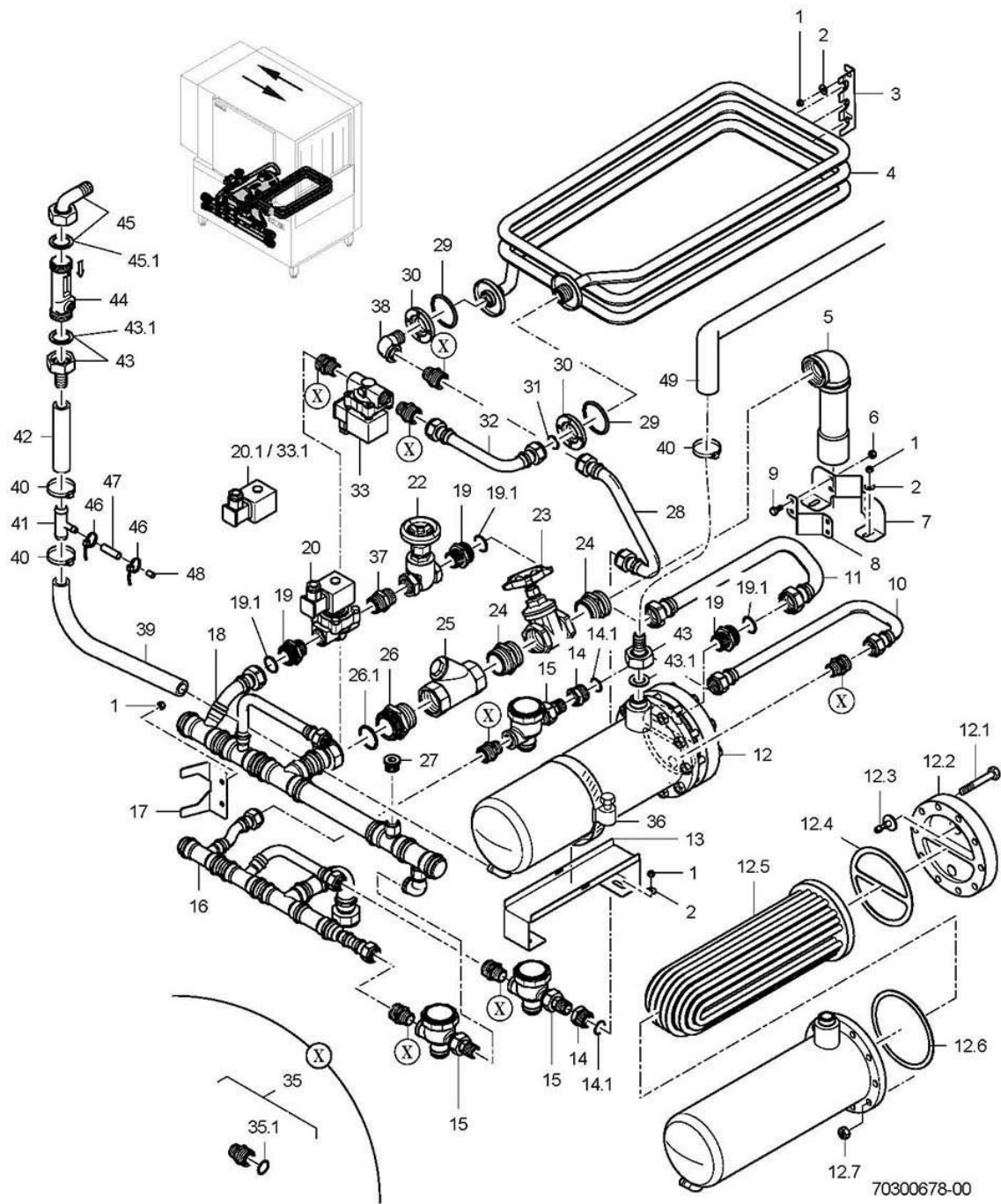

## STR

### Steam heating

Item.	Designation	Parts no.:	Pc.	Notes
22	Gate valve; G 3/4"	29 01 318		
23	Gate valve; 1 1/4"	29 01 319		
24	Double nipple; R 1 1/4", SW46	70009912		
25	Dirt trap; R 1 1/4" X 100	28 07 008		
26	Double nipple; G 1 1/2" X R 1 1/4";	70300680		incl. item 26.1
26.1	O-ring; 35,4 X 3,25	27 07 090		
27	Screw plug; G 1/2"	30 08 303		
28	Condensate drain elbow	70300451		
29	O-ring; 43 X 7,0	27 07 088	2	
30	Centring pressure plate; G 3/4" X 12, D59	70009508	2	
31	O-ring; 18 X 2,5 (18,2 X 2,6)	27 07 077		
32	Steam pipe elbow	70300453		
33	2/2-Way solenoid valve; R1/2";230-240V;50-60HZ	31 06 143		incl. item 33.1
33.1	Coil; 220V/50HZ	31 06 147		
33	2/2-Way solenoid valve; R1/2"; 220-230V; 60HZ	31 06 237		incl. item 33.1
33.1	Coil; 220V/60HZ	31 06 149		
33	2/2-Way solenoid valve; R1/2"; 200V; 50HZ	31 06 238		incl. item 33.1
33.1	Coil; 200V/50HZ	31 06 156		
33	2/2-Way solenoid valve; R1/2"; 200V; 60HZ	31 06 239		incl. item 33.1
33.1	Coil; 200V/60HZ	31 06 157		
35	Reducing nipple; G 3/4" X R 1/2"; SW27	70005633		incl. item 35.1
35.1	O-ring; 18 X 2,5 (18,2 X 2,6)	27 07 077		
36	Hose clamp; D50-145 X 12	28 02 008		
37	Hexagonal double nipple; R 3/4" X 40; SW30	30 11 021		
38	Elbow; G 1/2"	30 02 301		
39	Hose; DN12,5 X 3,5; 520	62003092		
40	Hose clamp; D12-22 X 9	28 02 105	4	
41	Hose T-connecting piece; D15 X D15 X D10	70010599		
42	Industrial hose; DN13 X 3,5	40 02 035		80 mm; "By-the-metre" goods
43	Hose coupling; R 3/4" X 1/2"	60002453		
43.1	Gasket; D16 X D24 X 3,0	80002241		
44	Flow regulator; 2 - 8 L/MIN	70010787		
45	Hose nipple, angled; D18	60002474		
45.1	Gasket; D16 X D24 X 3,0	80002241		
46	Cable tie; 100 X 2,5	31 20 175	2	
47	Hose; DN5 X 1,5	40 01 024		60 mm; "By-the-metre" goods
48	Bolt; D6 X 30	70200383		
49	Hose elbow 90°; DN12,5X4,0;45X880	62001434		



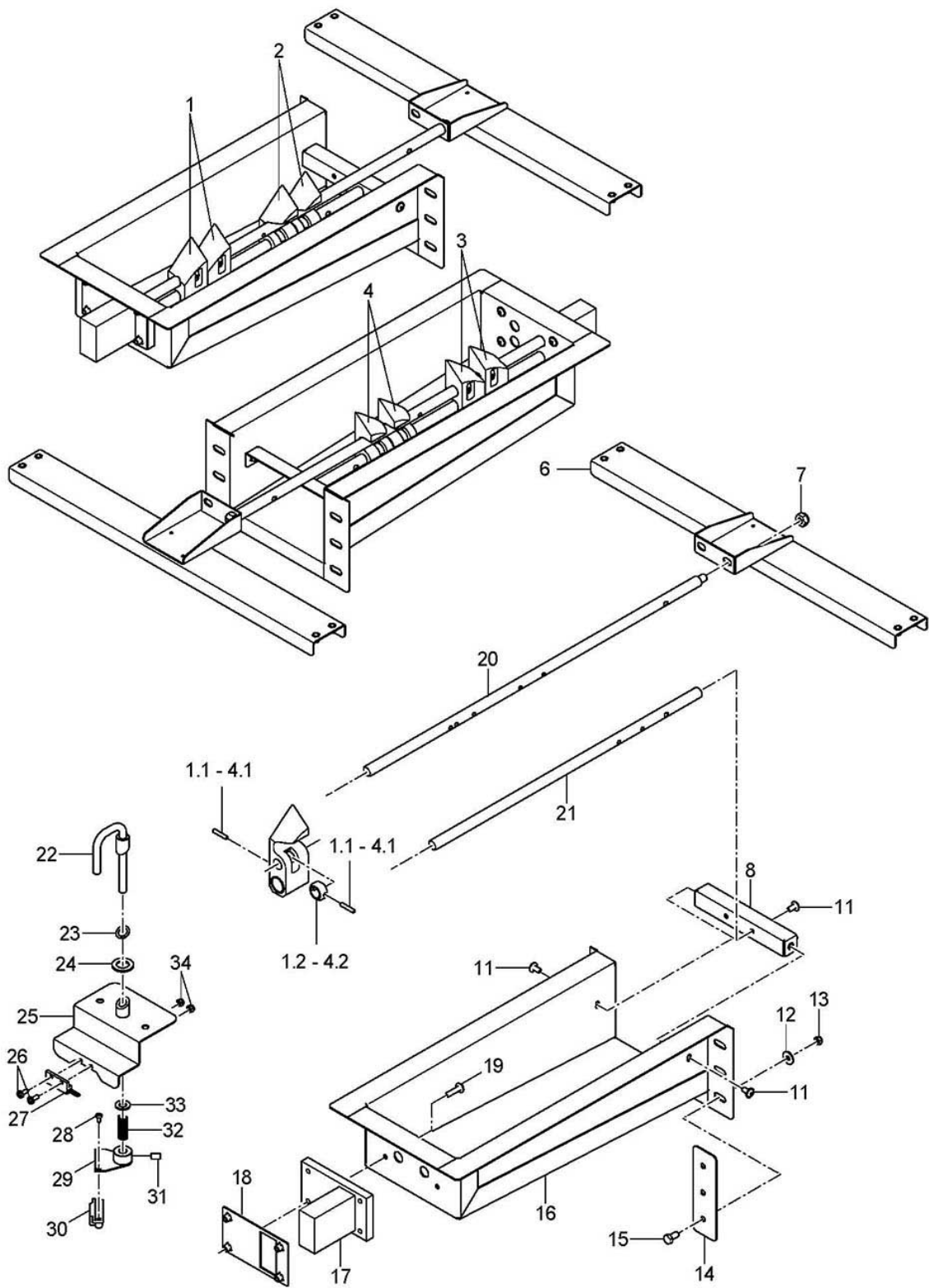

70300768-01

## STR

### Corner entry

Item.	Designation	Parts no.:	Pc.	Notes
1	Upper swivel cam, L-R	70010488	2	incl. item 1.1 - 1.2
1.1	Spring dowel pin; D4 X 20; FORM A	26 08 305	2	
1.2	Collar; D20 X 10	70010150		
2	Lower swivel cam, L-R	70010489	2	incl. item 2.1 - 2.2
2.1	Spring dowel pin; D4 X 20; FORM A	26 08 305	2	
2.2	Collar; D20 X 10	70010150		
3	Upper swivel cam, R-L	70010490	2	incl. item 3.1 - 3.2
3.1	Spring dowel pin; D4 X 20; FORM A	26 08 305	2	
3.2	Collar; D20 X 10	70010150		
4	Lower swivel cam, R-L	70010491	2	incl. item 4.1 - 4.2
4.1	Spring dowel pin; D4 X 20; FORM A	26 08 305	2	
4.2	Collar; D20 X 10	70010150		
6	Cross member	70300430		
7	Hexagonal nut; M8 SELBSTSICHERND	21 05 306		
8	Support angle	70300605		
11	Hexagon screw; M5 X 12; A70	20 01 323	3	
12	Washer; D6,4 X D18 X 1,6	22 05 302	6	
13	Hexagonal nut; M6 SELBSTSICHERND	21 05 304	6	
14	Cascade orifice; 1,5 X 35 X 113	70010282		
15	Hexagon screw; M6 X 16; A70	20 01 306	6	
16	Tray	70010235		
17	Bracket; 57 X 72 X 100	70010248		
18	Pressure plate	70010247		
19	Raised head screw with hexagon socket; M5 X 25 MIT FLANSCH	20 10 372	4	
20	Cam tension rod; M8 X 521	70010243		
21	Cam rod; D12 X 410	70010240		
22	Switch lever	75203516		
23	Washer; D10,5 X D15,5 X 1,0	31 20 199		
24	Gasket; D14 X D23,5 X 2,0	27 01 028		
25	Holder	75203519		
26	Raised head screw; M4 X 10	20 10 302	2	
27	Solenoid switch; 32 X 14,9 X 6,9;7000LG	31 24 276		
28	Sheet metal screw; ST 3,5 X 9,5	20 20 305	2	
29	Magnet holder	75203522		
30	Magnet holder; 12,9 X 15 X 40	61006243		incl. magnet
31	Grub screw; M6 X 8	20 30 304		
32	Pressure spring	75203962		
33	Washer; D8,4 X D17 X 1,6	22 01 303		
34	Hexagonal nut; M4 SELBSTSICHERND	21 05 300	2	